



Instruction & Operation Manual



STEAM HUMIDIFIER ElectroVap® Series RTH-HC

ELECTROVAP® RTH-HC

Contents

1.	SAFETY INSTRUCTIONS	3
1.1.	INTRODUCTION	3
1.2.	IMPORTANT INFORMATION	4
1.3.	DECLARATION OF CONFORMITY	5
1.4.	RoHS DECLARATION	5
2.	PRODUCT PRESENTATION	6
2.1	CHARACTERISTICS	6
2.2	Dimensions	7
2.3	HUMIDIFIER CONSTRUCTION	8
2.4	IMPORTANT instructions	9
3.	INSTALLATION	10
3.1	PROCEDURE	10
3.2	water supply connection	11
3.3	STEAM OUTLET	12
3.4	CONDENSATE DRAIN WITH SIPHON	13
3.5	DRAIN HOSE CONNECTION	13
3.6	ELECTRICAL CONNECTIONS	15
3.6.1	Technical Data	15
3.7	ELECTRICAL WIRING	17
3.8	Option: REMOTE INFORMATION BOARD	18
3.9	ELECTRICAL WIRING DIAGRAMS	19
3.10	CONTROL SIGNAL CONNECTION	25
3.10.1	On/Off Control And Safety Contacts	25
3.10.2	Proportional control	25
3.10.3	RS485 connection	26
3.10.4	MODBUS RTU and BACNET MSTP Communication Parameters	26
3.10.4.1	Standardized Bacnet Protocol Implementation Sheet	27
3.10.4.2	MODBUS RTU & BACNET MSTP Communication Parameters	27
3.10.4.3	Communication Protocol for RS485 interface - MODBUS and BACNET	27
3.11	wiring diagrams	30
3.12	Water level sensor wiring	33
4.	COMMISSIONING	34
5.	SYSTEM MANAGEMENT	35
5.1	Information menu (read-only)	35
5.2	SETUP menu	37
5.3	control SYSTEM MENU	38
5.4	menu: HUMIDIFIER CONFIGURATION	40
5.5	MAINTENANCE ALERTS	43
5.6	DEFAULT MESSAGES	44
6.	MAINTENANCE	50
6.1	STAINLESS STEEL TANK	50
6.2	DRAIN VALVE	51
6.3	WATER INLET VALVE	52
6.4	water level sensor	52
7.	SPARE PARTS	53
7.1	STAINLESS STEEL cUVE	53
7.2	Water inlet solenoid valve	54
7.3	Water level sensor	54
7.4	Drain solenoid valve	54
7.5	Electrical part	55

ELECTROVAP® RTH-HC





1. SAFETY INSTRUCTIONS

1.1. INTRODUCTION

You've recently purchased the ElectroVap® RTH-HC humidifier, and we hope you enjoy this product. Thank you for the trust you place in us. The safety instructions contained in this manual are intended for specialized, qualified personnel who are authorized to install, commission and maintain the unit.

To get the best results from your humidifier, we recommend :

- Read the instructions in this manual carefully;
- Keep this manual in a safe place for future reference;
- Please pass on this manual in the event of sale or transfer of the unit, to ensure that all relevant information is passed on;

SAFETY WARNINGS AND SYMBOLS USED IN THIS MANUAL	
	Danger! Caution. General safety instructions, violation of which could lead to malfunctions and/or personal injury and/or property damage.
	Danger! High voltage. If high voltages are present inside the device or any of its components, failure to heed this warning may result in death or serious injury to the user. people and/or major equipment malfunctions.
	Danger! High temperatures. Make sure that protective equipment is worn and keep a safe distance from the machine. between the device and any materials likely to be damaged by heat.
	Electrostatic hazard. Device components may be subject to damage as they are highly sensitive to electrostatic discharge.
	Möbius strip. Some parts of the device can be recycled. The user is responsible for their disposal. Follow the recycling recommendations adapted to the materials used in your area.

- If the package is damaged, please make a claim to your carrier by registered letter with acknowledgement of receipt within 24 hours and make a declaration to your Devatec representative.
- Pictures, graphics and values are subject to change without notice.
- Keep these instructions in a safe place, and if you have any questions which are not answered in this manual, please do not hesitate to contact us or your Devatec representative.

Our team is ready to listen!

ELECTROVAP® RTH-HC

1.2. IMPORTANT INFORMATION

GENERAL	<p>This manual is a translation of the original French version. It contains full details of installation, commissioning and maintenance of the ElectroVap® RTH-HC humidifier.</p> <p>Maintenance, service and repairs, as well as the study of the risks and dangers associated with these operations, must be carried out by qualified, competent and authorized personnel.</p> <p>Make sure that any risks or hazards, especially when working at height, are defined in advance by an authorized person.</p> <p>We also recommend installing a safety perimeter. Make sure the power supply is disconnected before carrying out maintenance.</p> <p>Please tighten all power cable terminals periodically.</p>
INTENDED USE	<p>The ElectroVap® RTH-HC humidifier manufactured by Devatec is designed exclusively for humidifying air in air handling units and rooms.</p> <p>The user undertakes to use the equipment in accordance with the safety rules set out in this documentation.</p> <p>Improper use may result in danger and serious damage to the user, third parties and equipment.</p>
STORAGE & HANDLING	<p>The unit must be stored in a dry, frost-proof place, protected from shocks and vibrations. Handling must be carried out by at least two people or by suitable lifting equipment.</p>
WATER	<p>Steam humidifiers can be used with potable, demineralized or softened water. It is absolutely forbidden to inject chemicals into the hydraulic system. Ensure that the water supply pressure does not exceed 8 bar. Always ensure that the installation complies with local standards.</p>
ELECTRICITY	<p>The user guarantees that the electrical installation work will be carried out by a qualified technician. It is the installer's responsibility to provide the correct cable cross-section and thermal-magnetic circuit breaker protection, in accordance with the regulations in force in the country of installation. Ensure that the humidifier is earthed with a suitable conductor.</p>
GUARANTEE	<p>Devatec warrants its units for 12 months from date of installation and 15 months from date of shipment; excluding wear parts, labor and the following wear parts: water supply solenoid valve, drain solenoid valve, heating resistor, contactor and solid state relay are warranted for 6 months.</p> <p>Devatec's liability shall be limited exclusively to the repair or replacement by Devatec of the part or product, excluding labor or other disassembly or installation costs. At its discretion, Devatec may also decide to refund the purchase price of the part or product. Failure to comply with the above recommendations, additional assembly and/or conversion using components other than those supplied with the device, or any other use other than that intended, will be considered as non-compliance with the prescriptions and will invalidate the warranty.</p>
RESPONSIBILITY	<p>Devatec accepts no liability for faulty installation or improper use of the equipment and its components.</p> <p>We strive to provide you with a manual that is as comprehensive as possible. However, conditions in the air handling industry are such that the information contained in this documentation may be subject to change without notice.</p>

ELECTROVAP® RTH-HC

1.3. DECLARATION OF CONFORMITY

The devices, identified by serial numbers between 600 000 and 699 999, meet the requirements of the following European directives:

2014/30/EU

2014/35/EU

DEVICE TYPE	Humidifier
MODEL NAME	RTH-HC
BUILDER	Devatec 185 Boulevard des Frères Rousseau 76550 Offranville - FRANCE

We hereby declare that the equipment specified above conforms to the directives mentioned at the beginning of this declaration. This applies to units numbered 600 001 to 699 999.

FRAMBOT Jean-François

General Manager

05/01/2021



1.4. ROHS DECLARATION

Devatec,

Confirms that the ElectroVap® RTH-HC humidifier is manufactured in compliance with the following European regulations:

2011/65/EU (RoHS)

These regulations govern the use of mercury, cadmium, lead (in welding processes), chromium VI as well as PBB and PBDE after July 1, 2006.

MINFRAY Jean-Marie

R&D Engineer

05/01/2021



ELECTROVAP® RTH-HC

2. PRODUCT PRESENTATION

2.1 CHARACTERISTICS

The RTH-HC humidifier is an electric humidifier designed for air humidification in AHUs or rooms. Like all humidifiers in the range, it is compatible with our BlowerPack ventilation unit.

Standard delivery includes :

1. Steam humidifier
2. Technical documentation
3. 3 hose clamps per tank (2 for the steam hose and 1 for the drain hose)

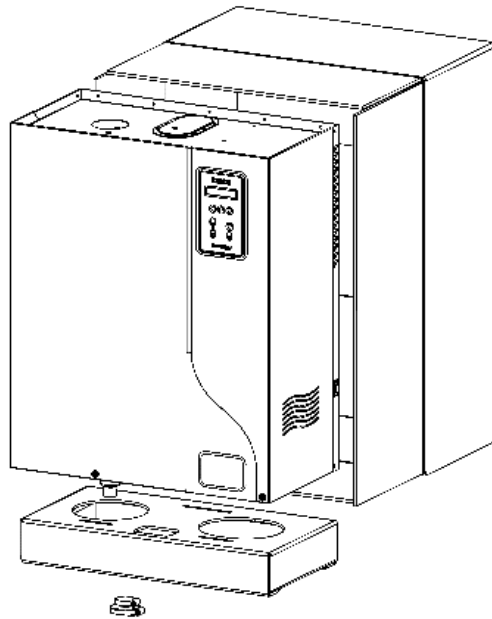

Fig. 2-1. Humidifier

ACCESSORIES (Not supplied)

- Stainless steel steam tubes
- ExpressPack®
- BlowerPack fan unit
- Steam and condensate hoses
- Duct or room humidity transmitter
- High-limit hygostat
- 3/4" FF stainless steel braided hose (with gaskets) for connection to the water network.
- Drain hose
- Remote Information Board
- Filling cup extension
- Transformateur 3x380-600V/2x115V
- Additional cooling kit
- Outdoor protective cabinet
- Mounting bracket
- Collecting Water Tank

ELECTROVAP® RTH-HC

2.2 DIMENSIONS

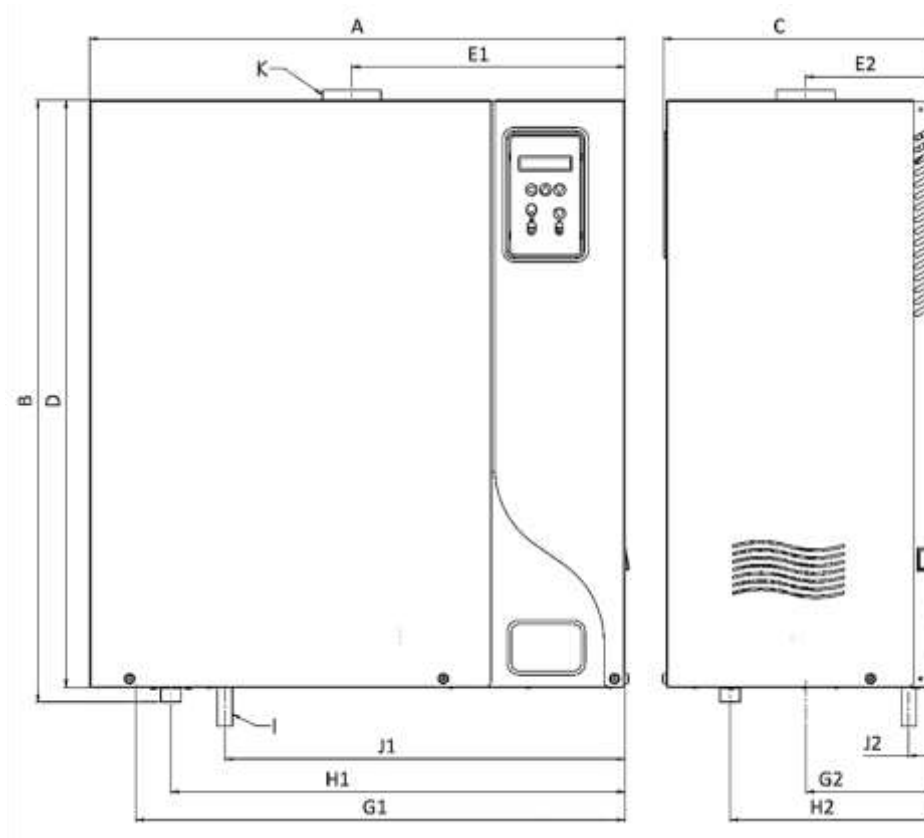

Fig. 2-2. Humidifier sizes

	RTH-HC 5-50	RTH-HC 60-100
Number of steam outputs	1	2
Dimension [mm] / [in]		
A: Width	686 / 27.01	1124 / 44.26
B: Height	770 / 30.32	770 / 30.32
C: Depth	343 / 13.51	350 / 13.78
D: Cabinet height	751 / 29.57	751 / 29.57
E1: Steam outlet position	360 / 14.18	360 / 14.18
E2: Steam outlet position	165 / 6.5	165 / 6.5
E3: Distance between steam outlets		592 / 23.31
G1: Drain position	629 / 24.77	641 / 25.24
G2: Drain position	163 / 6.42	291 / 11.46
H1: Water inlet position	582 / 22.92	702 / 27.64
H2: Water inlet position	261 / 10.28	261 / 10.28
I: Overflow diameter	12 / 0.48	12 / 0.48
J1: Overflow position	642 / 25.28	732 / 28.82
J2: Overflow position	32 / 1.26	32 / 1.26
K: Steam outlet diameter	60 / 2.37	60 / 2.37
Weight [kg] / [lb]		
Operating weight	75 / 166	140 / 309
Packed weight	45 / 100	70 / 155

ELECTROVAP® RTH-HC

2.3 HUMIDIFIER CONSTRUCTION

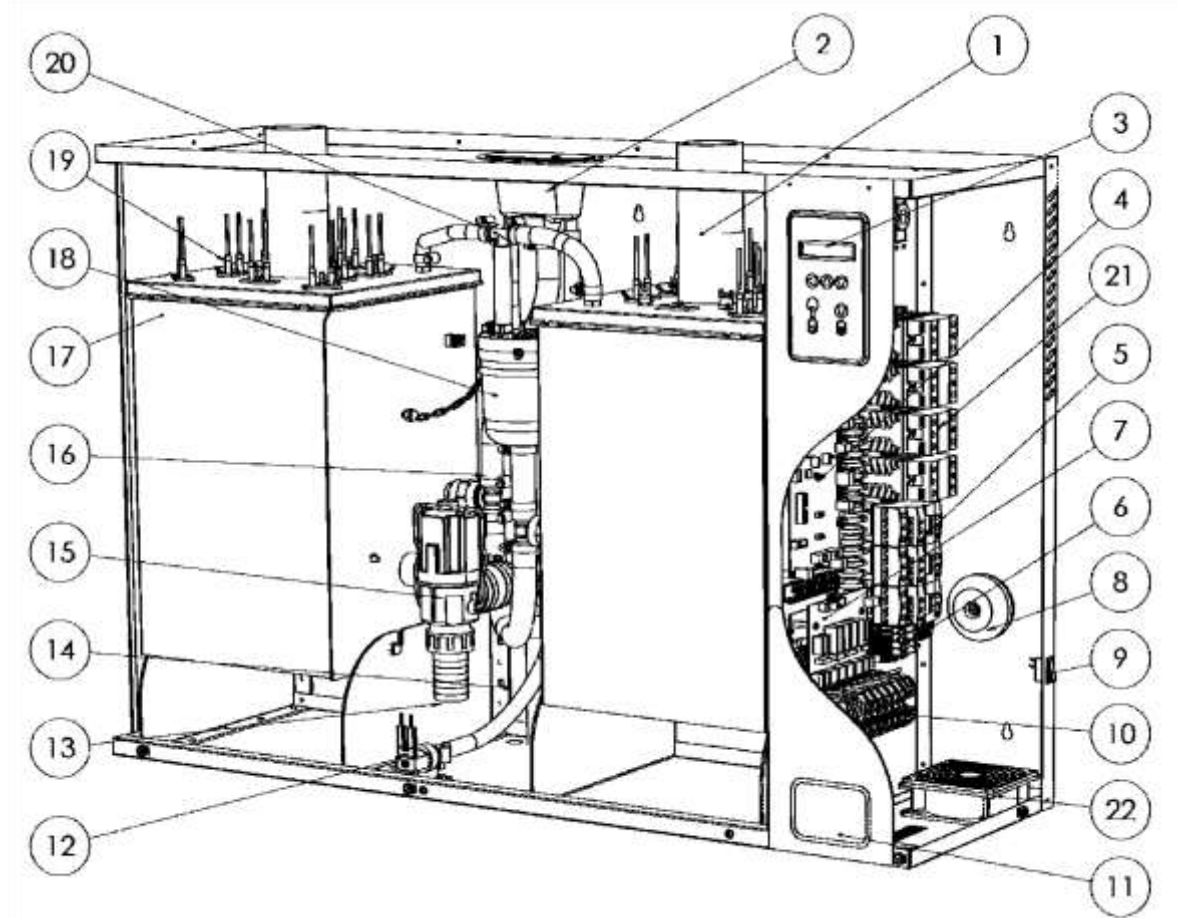

Fig. 2-3. Humidifier construction

1	Steam hose (optional)	12	Water inlet solenoid valve
2	Filling cup	13	Drain hose connection
3	Display board	14	Overflow pipe
4	Main board	15	Drain valve
5	Contactor	16	Filling hose
6	Fuse holders	17	Tank
7	3-relay board (optional)	18	Water level sensor
8a	Transformer 2x115 / 2x12V S: 50VA	19	Immersion heater
9	ON / OFF switch	20	Pressure balancing
10	Power rail	21	Static relay
11	Identification label	22	Fan

ELECTROVAP® RTH-HC

2.4 IMPORTANT INSTRUCTIONS

- Ambient temperature: between 5°C and 40 °C
- Ambient humidity : < 80% Relative humidity
- Back side panel: this component heats up during operation (up to 60°C). Make sure that the construction on which the device is to be mounted is not a heat-sensitive material.
- Wall mounting: Please ensure that the supporting material (pillar, wall, etc.) is able to withstand the device.
- Fixation: use a fastening system adapted to the support material.
- Carefully observe the below distances when installing your device.

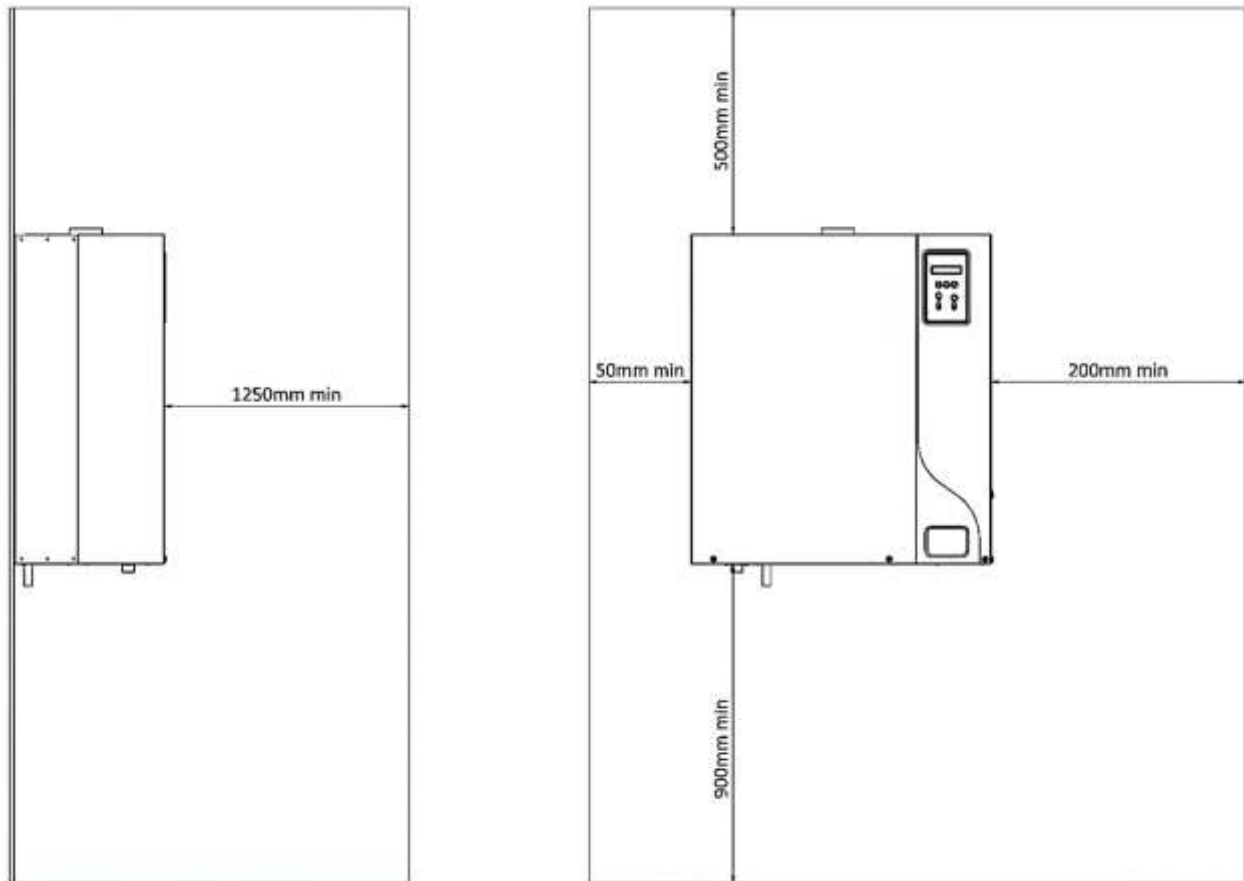

Fig.2-4. *Mounting distances*



Please read and follow the safety information in the manual and the warning labels inside the humidifier before installation or maintenance.

Some steps can be dangerous.

Visit our website or contact our operators for technical assistance.

ELECTROVAP® RTH-HC

3. INSTALLATION

3.1 PROCEDURE

- Mark and drill where indicated (hole size depends on the plugs and support materials chosen).
- Put the dowels in the holes.
- Screw the top screws into the dowels (M6 recommended), leaving them protruding by about 10 mm/0.39in.
- Hang the unit on the top screws and align it vertically and horizontally using a spirit level.
- Tighten up all screws.

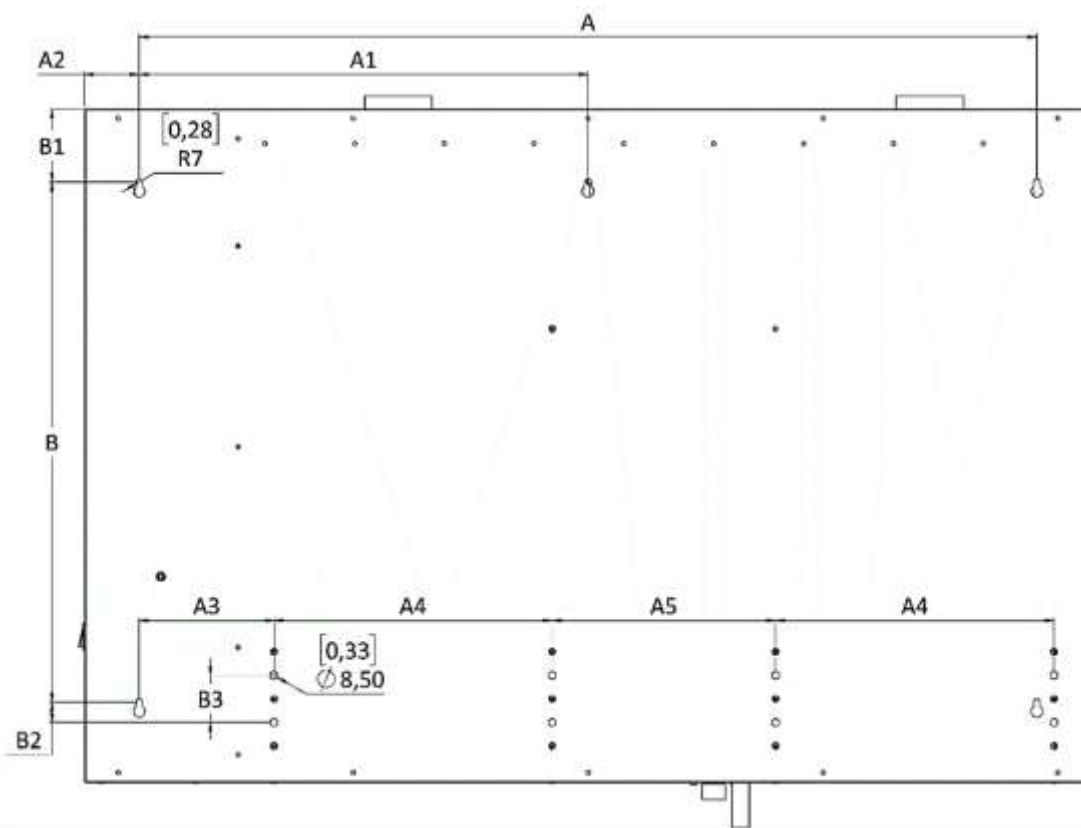

Fig. 3-1. Mounting hole location

	RTH-HC 5 - 50	RTH-HC 60 - 100
	[mm]/ [in]	
A	640 / 25.2	1000 / 39.38
A1	22 / 0.87	500 / 19.69
A2		61 / 2.41
A3	201 / 7.92	160 / 6.3
A4	301 / 11.86	310 / 12.21
A5		239 / 9.41

	RTH-HC 5 - 50	RTH-HC 60 - 100
	[mm]/ [in]	
B	580 / 22.84	580 / 22.84
B1	81 / 3.19	81 / 3.19
B2	23 / 0.91	23 / 0.91
B3	53 / 2.09	53 / 2.09

ELECTROVAP® RTH-HC

3.2 WATER SUPPLY CONNECTION

3.2.1 Recommendation

Our device is designed for use with the following types of water:

- ✓ Drinking water (in compliance with directive 98/83/EEC), TH (French degrees) between 0° fH and 40° fH with conductivity between 250 µS/cm and 1000 µS/cm
- ✓ Softened water, use possible only under certain conditions. Please contact us.
- ✓ Demineralized water, reverse osmosis water.

Fig. 3-2. Humidifier water supply

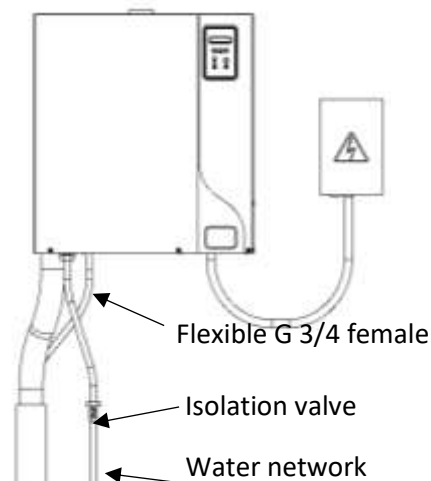

Demineralized water is corrosive, so use only pipes designed for this purpose (stainless steel, PVC).

Softened water: Not recommended, but possible. **TH 12 °fH minimum.**

A water analysis is recommended to determine sodium chloride levels.

If you have any questions about the quality and levels of your water, please do not hesitate to contact us.



Excessive concentrations of sodium chloride can cause foaming or scumming, which is detrimental to proper operation. It is therefore imperative to use **duplex softeners**. **Maximum chloride content: 80 mg/l**

3.2.2 Connection recommendations

Mains water pressure: Pressure must be stable and between 2 bar and 8 bar MAX.

Mains water temperature: < 40°C.

Please note that the water connection is made at the foot of the unit.

For ease of maintenance, the humidifier is fitted with a filter strainer that should be checked periodically. To facilitate maintenance, an isolation valve should be installed close to the humidifier.



RISK OF WATER OVERFLOW: we recommend installing a drip tray (optional) under the humidifier to prevent any risk of water overflow. This is essential if the unit is installed in a suspended ceiling or above a sensitive area (e.g. museum hall, exhibition room, laboratory, etc....). Equip the tank with a drainage system.

ELECTROVAP® RTH-HC

3.3 STEAM OUTLET

1. Preferably use a flexible steam hose resistant to a temperature of 100°C.

NB: when new pipes are installed, a smell of burnt plastic may appear when the steam humidifier is first turned on. This smell is normal and will diminish.

2. Steam hose selection :

Model	RTH-HC 5 to 50	RTH-HC 60 to 100
Number of steam outlets	1	2
Steam outlet diameter	Ø 60 mm	Ø 60 mm

3. The RTH-HC humidifiers can operate with a pressure (P) higher than the atmospheric pressure in the ducts, but under the following conditions:

- If P is less than 2157 Pa, i.e. a water column greater than 220mm, operation is standard.
- If P exceeds 2157 Pa, i.e. a water column greater than 220mm, options are available.
- If P is greater than 11,768 Pa, i.e. a water column greater than 1200 mm, please contact your sales representative.

4. To install the steam pipe in your environment, please follow the recommendations below and use the appropriate tangential clamps.

- Flexible steam hose, max. length 3 m.
- Rigid stainless steel or copper pipe, slightly larger diameter, grounded. The humidifier must be connected to the rigid steam pipe by a flexible steam pipe sleeve. The length of the pipe should not exceed 6 m, and it should be insulated.



Always slope in the same direction (upwards or downwards); the steam pipe must be free of bends and kinks to allow condensate to drain by gravity. Ensure that the steam pipe is free from leaks. Failure to comply with these instructions may result in serious malfunctions.

Steam pipe bending radius diameter :

- Ø 60 - 600mm minimum

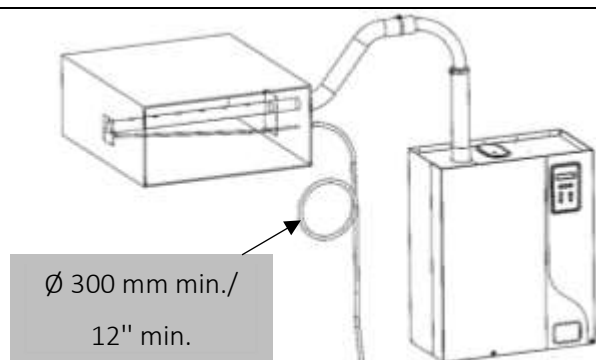

Fig. A 3-4. Standard installation

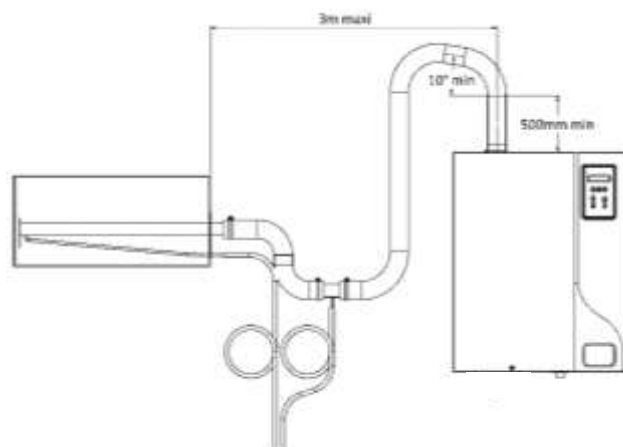

Fig. B 3-4. Additional drip leg when steam is distributed under the humidifier

ELECTROVAP® RTH-HC

3.4 CONDENSATE DRAIN WITH SIPHON

POSITIVE PRESSURE SIPHON

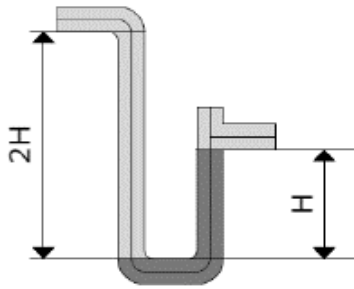

Fig. A 3-5.

NEGATIVE PRESSURE SIPHON

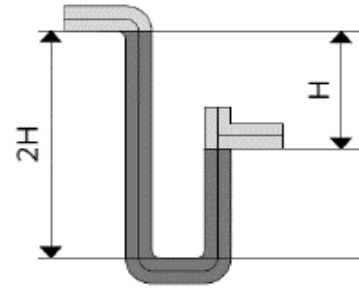

Fig. B 3-5.

The condensate pipe must not be connected directly to the public sewage system.

$$H \text{ min. (mm)} = P \text{ (Pa)} / 10$$

with P = absolute pressure of the air handling unit or ventilation duct

3.5 DRAIN HOSE CONNECTION

The following drawing shows how to connect the drain hose.

Use a \varnothing 40 mm rubber drain hose with the 2 hose clamps supplied, heat-resistant (up to 100°C). Connect the hose to the drain system. Regular replacement is recommended.

If you use a rigid pipe, it must be made of heat-resistant PVC (up to 100°C).

The drain hose must be free of obstructions.

We recommend that each humidifier has its own drain hose.

If possible, use a water collection tray with a lid (see photo below).

For manifolds installation and recommendations, see accessory documentation.

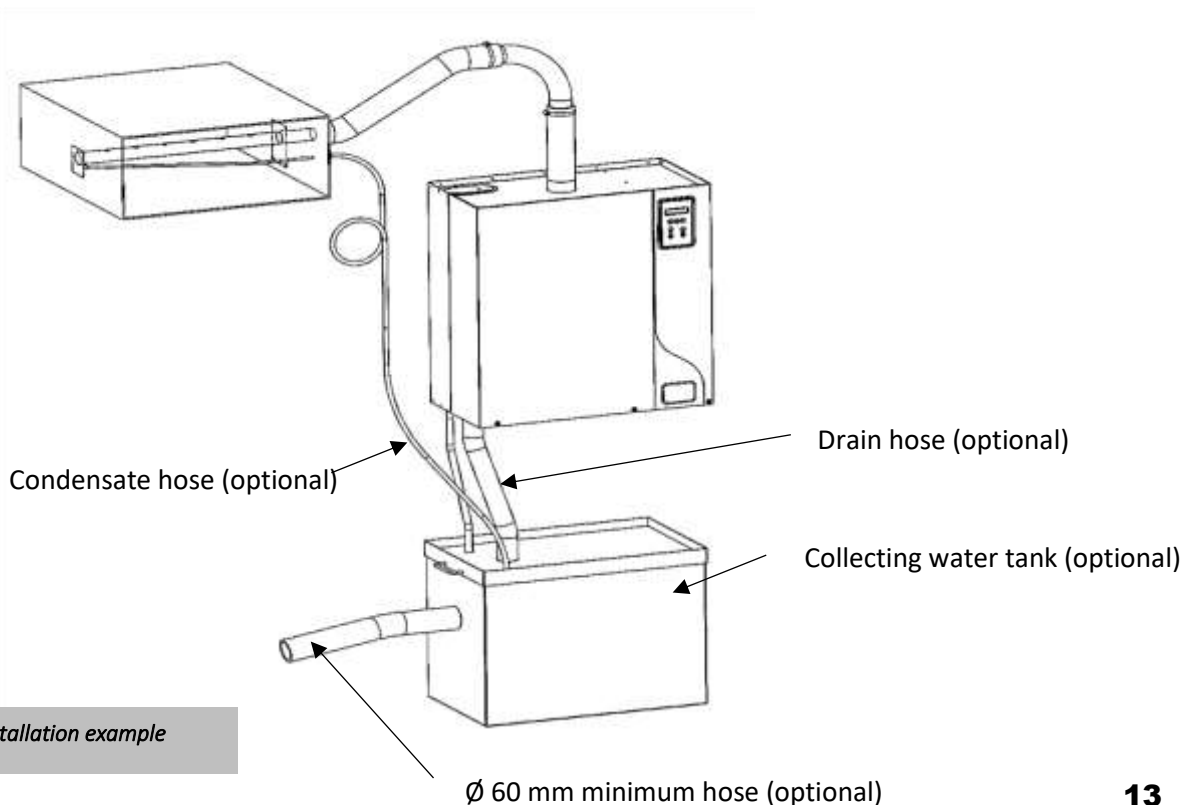

Fig. A 3-6. Installation example

ELECTROVAP® RTH-HC



Maintain a minimum downward slope (α) of 10° for the generator drain and overflow pipes, and for the general drain pipe.



The drain hose should be inserted about 8 cm into the collecting water tank (the hose must never come into contact with the waste water in the tank).

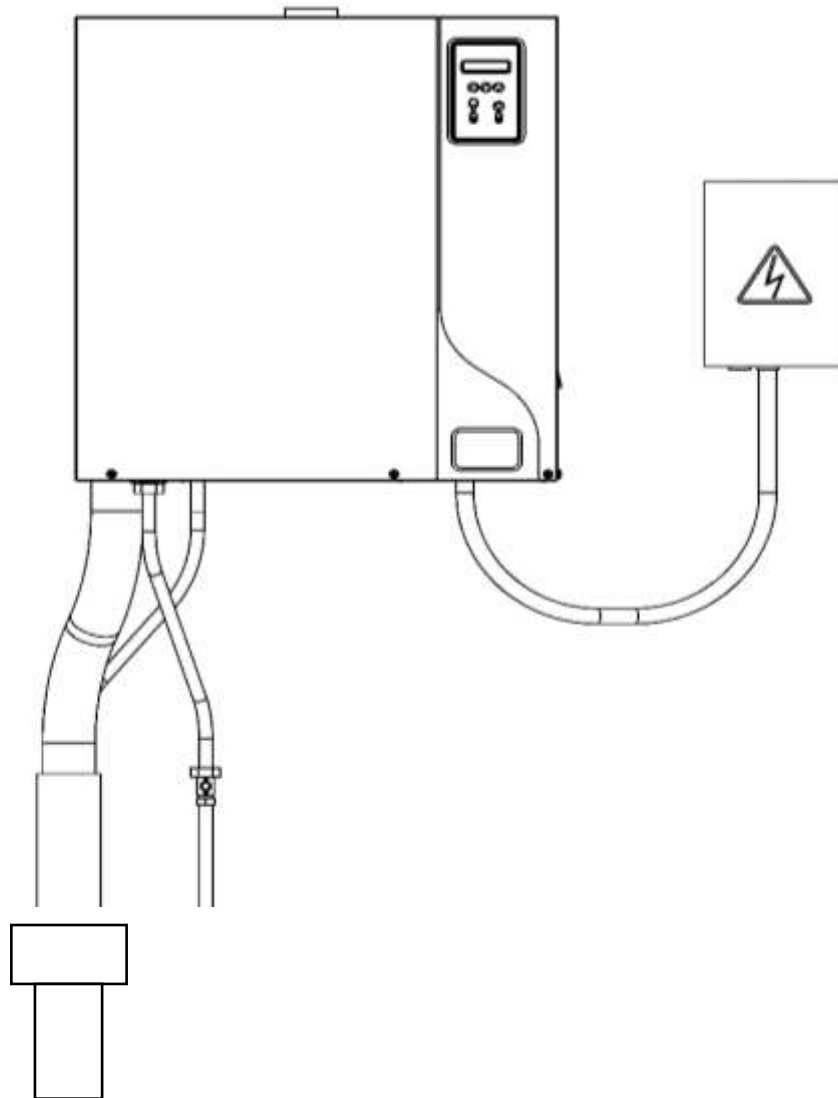

Fig. A 3-6. *Installation example*

ELECTROVAP® RTH-HC

3.6 ELECTRICAL CONNECTIONS

3.6.1 Technical Data

Voltage (V)	RTH -HC	3	5	7	8	10	15	20	30	40	50	60	70	80	90	100
	kg/h	2.5	5.7	-	8.3	-	-	-	-	-	-	-	-	-	-	-
	kW (Pn)	1.9	4.3	-	6.2	-	-	-	-	-	-	-	-	-	-	-
	I (A)	8.3	18.7	-	27.1	-	-	-	-	-	-	-	-	-	-	-
	kg/h	-	-	-	6.2	-	-	-	-	-	-	-	-	-	-	-
	kW (Pn)	-	-	-	4.7	-	-	-	-	-	-	-	-	-	-	-
	I (A)	-	-	-	13.0	-	-	-	-	-	-	-	-	-	-	-
	kg/h	-	-	-	7.6	-	-	-	-	-	-	-	-	-	-	-
	kW (Pn)	-	-	-	5.7	-	-	-	-	-	-	-	-	-	-	-
	I (A)	-	-	-	14.4	-	-	-	-	-	-	-	-	-	-	-
	kg/h	-	4.7	6.9	-	10.8	15.6	21.5	26.4	38.1	46.8	53.7	62.5	76.3	85	93.7
	kW (Pn)	-	3.6	5.2	-	8.1	11.7	16.2	19.8	28.7	35.2	40.4	47.0	57.3	63.9	70.4
	I (A)	-	5.5	7.9	-	12.4	18	24.8	30.3	43.9	53.9	61.8	71.9	87.7	97.8	107.8
	kg/h	-	5.3	7.6	-	11.9	17.3	23.9	29.2	42.2	51.9	58.5	69.2	84.5	94.2	103.8
	kW (Pn)	-	4.0	5.7	-	9.0	13.0	17.9	22.0	31.8	39	44.0	52.0	63.5	70.8	78.1
	I (A)	-	5.8	8.4	-	13.0	18.9	26.1	31.9	46.2	56.7	63.9	75.6	92.3	102.9	113.4
	kg/h	-	5.7	8.2	-	12.8	18.6	25.7	31.5	45.5	55.9	64.1	74.5	91.0	101.3	111.7
	kW (Pn)	-	4.3	6.2	-	9.7	14.0	19.3	23.7	34.2	42.0	48.2	56.0	68.4	76.2	84.0
	I (A)	-	6.0	8.7	-	13.5	19.6	27.1	33.1	47.9	58.9	67.5	78.5	95.8	106.8	117.7
	kg/h	-	-	6.4	-	-	14.4	20.8	28.9	35.2	43.3	49.7	57.7	70.5	78.5	86.6
	kW (Pn)	-	-	4.8	-	-	10.9	15.6	21.7	26.5	32.6	37.4	43.4	53.0	59.1	65.1
	I (A)	-	-	6.3	-	-	14.3	20.7	28.7	35.0	43.0	49.4	57.4	70.0	78.0	86.0
	kg/h	-	-	7.0	-	-	15.8	22.7	31.6	38.5	47.3	54.3	63.1	77.0	85.9	94.7
	kW (Pn)	-	-	5.2	-	-	11.9	17.1	23.7	29	35.6	40.8	47.4	57.9	64.5	71.2
	I (A)	-	-	6.6	-	-	15.0	21.6	30.0	36.6	45.0	51.6	60.0	73.2	81.6	90.0
	kg/h	-	-	7.6	-	-	17.2	24.8	34.4	41.9	51.5	59.1	68.7	83.9	93.5	103.1
	kW (Pn)	-	-	5.7	-	-	12.9	18.6	25.8	31.5	38.7	44.5	51.7	63.1	70.3	77.5
	I (A)	-	-	6.9	-	-	15.6	22.6	31.3	38.2	46.9	53.8	62.6	76.4	85.1	93.9
	kg/h	-	-	7.0	-	-	15.8	22.8	31.6	38.6	47.4	54.4	63.2	77.1	86.0	94.8
	kW (np)	-	-	5.2	-	-	11.9	17.1	23.8	29.0	35.6	40.9	47.5	58.0	64.6	71.3
	I (A)	-	-	5.3	-	-	12.0	17.3	24.0	29.3	36.0	41.3	48.0	58.6	65.4	72.1
	kg/h	-	-	7.6	-	-	17.2	24.8	34.4	42	51.6	59.2	68.8	84.8	93.6	103.2
	kW (np)	-	-	5.7	-	-	12.9	18.6	25.9	31.6	38.8	44.5	51.7	63.2	70.4	77.6
	I (A)	-	-	5.5	-	-	12.5	18.1	25.1	30.6	37.6	43.1	50.1	61.2	68.2	75.2

ELECTROVAP® RTH-HC

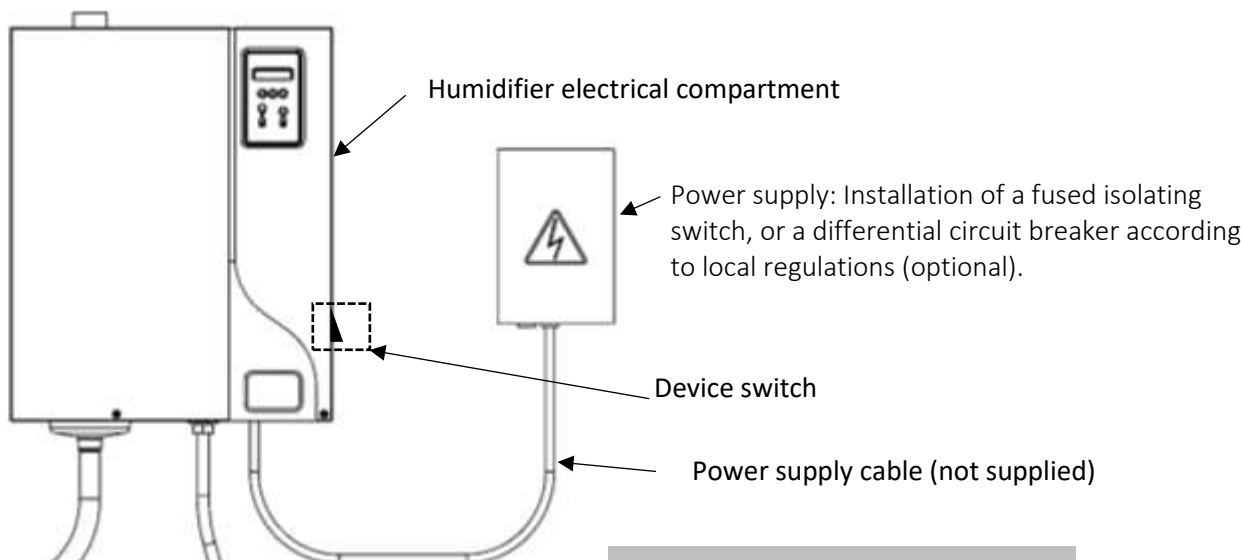

Fig. A 3-7. Electrical connections



All wires must enter the unit through a cable gland (not supplied).



Device switch: when the device is switched off, there is still voltage inside. **Electric shock can be fatal, so the power switch must be turned off.**



Connections to terminals: L1, L2, L3 (35mm²), and L, N (16mm²) must be made with copper wires.



All work on electrical parts must be carried out by qualified and authorized personnel. In addition, before making any electrical connections, check that your installation has been determined using the values in the table on page 21.



Electronic components are sensitive to electrostatic discharge. Observe local regulations regarding electrical connections.

ELECTROVAP® RTH-HC

3.7 ELECTRICAL WIRING

Up [V] = POWER VOLTAGE

Uc [V] = CONTROL VOLTAGE

Up(V) = 1x200 - 230Vac (50-60Hz)

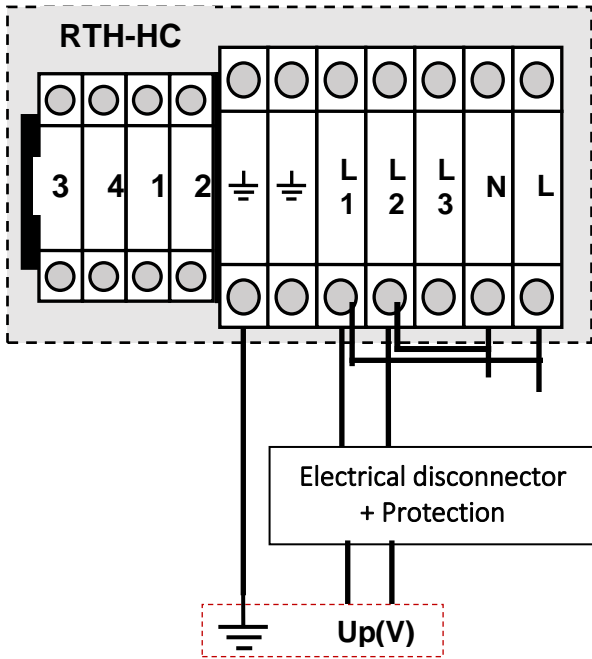

Up(V) = 3x200 - 230Vac (50-60Hz)

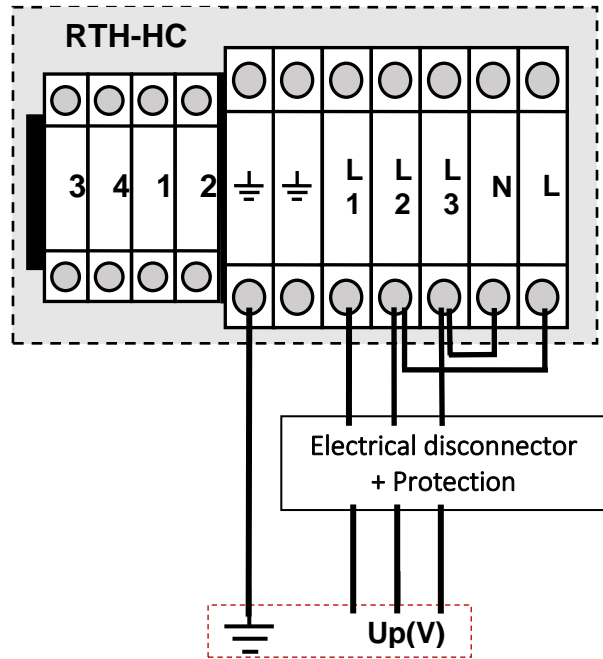

Up(V) = 3x380 - 420Vac (50-60Hz) with neutral

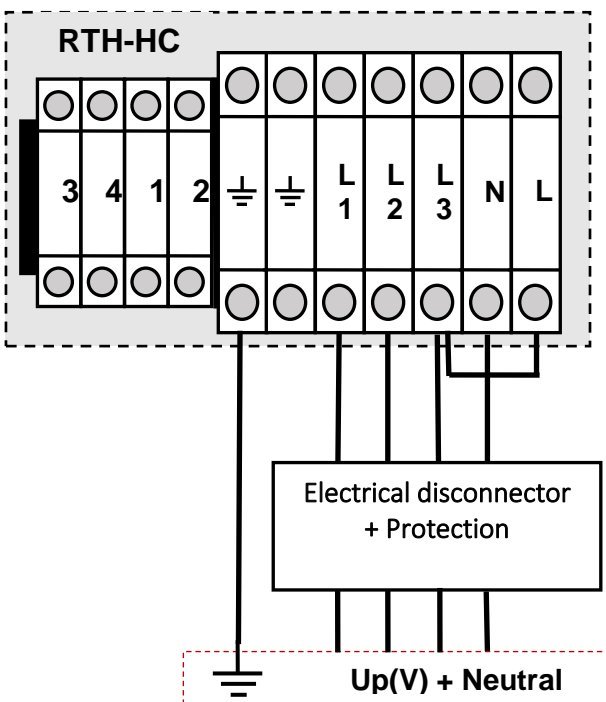

Up(V) = 3x380 - 690Vac (50-60Hz)

Uc (V) = 1x200 - 230Vac (50-60Hz)

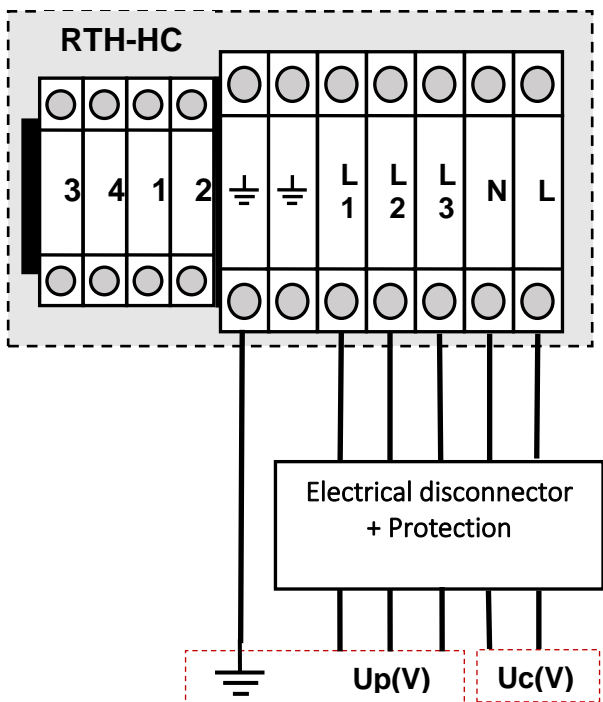

ELECTROVAP® RTH-HC

Up(V) = 3x380-690Vac (50-60Hz)

With **OPTION**: Transformer: dry: 2x115V

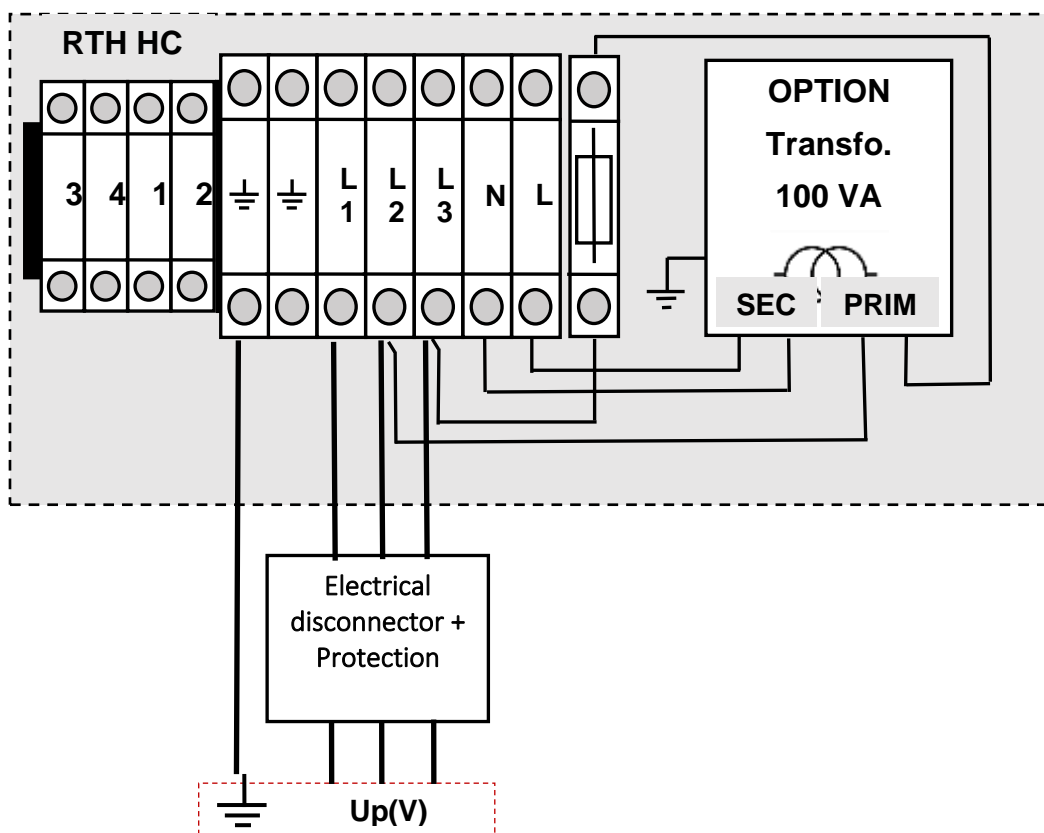

3.8 OPTION: REMOTE INFORMATION BOARD

A NO or NC contact can be selected by connecting as shown below (e.g. connection to 30 and 31 = NO contact).

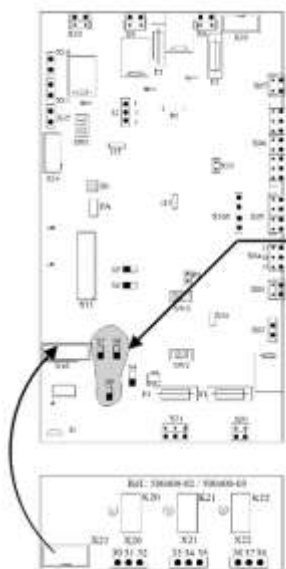

Check jumper S7, S8, S9.

Control of terminal blocks :

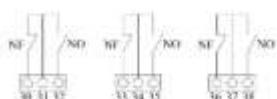

- X20 (30-31-32) : Dry contact for tank maintenance return.
- X21 (33-34-35) : Dry contact for general fault return.
- X22 (36-37-38): Dry contact for steam generation.

ELECTROVAP® RTH-HC

3.9 ELECTRICAL WIRING DIAGRAMS

Up[V] - 1x200-240V 50-60Hz

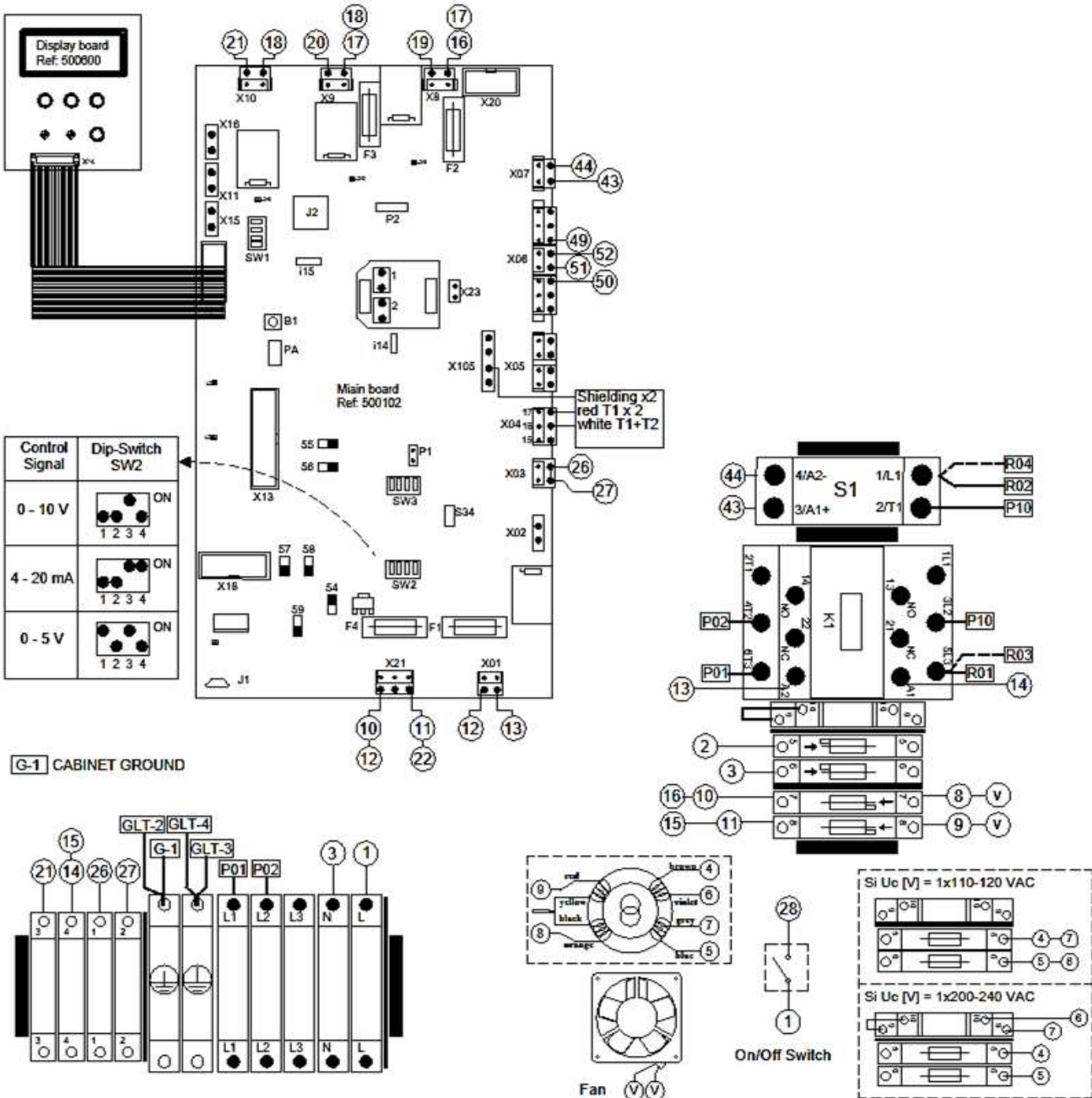
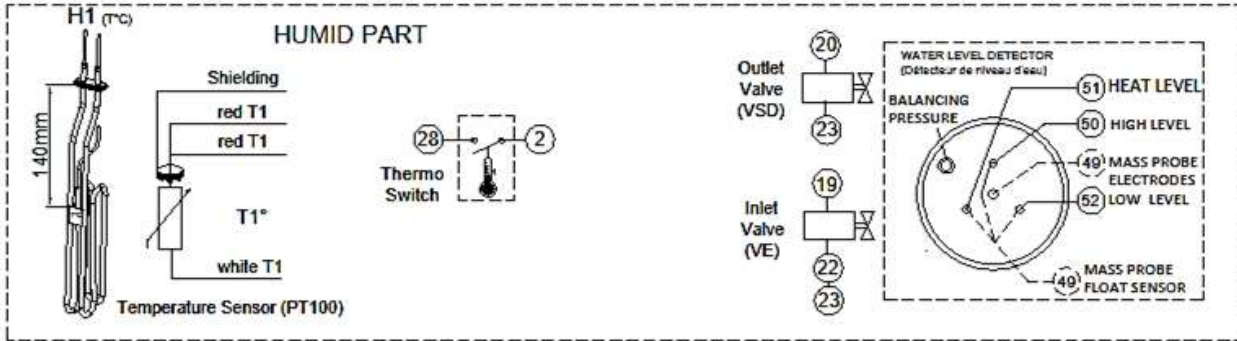

ELECTROVAP® RTH-HC

RTH-HC 8-18, Up[V] - 3x200-240V 50-60Hz

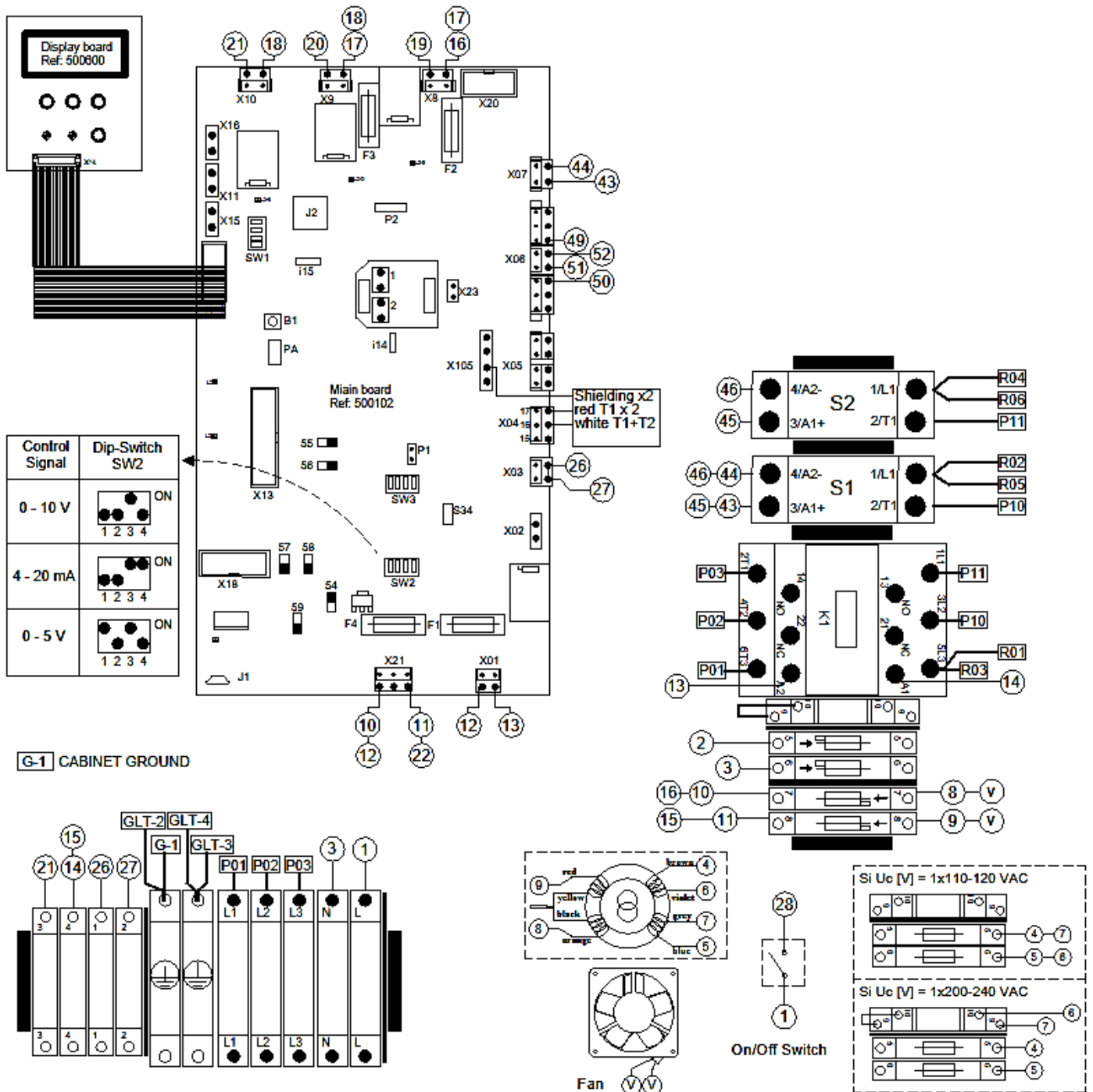
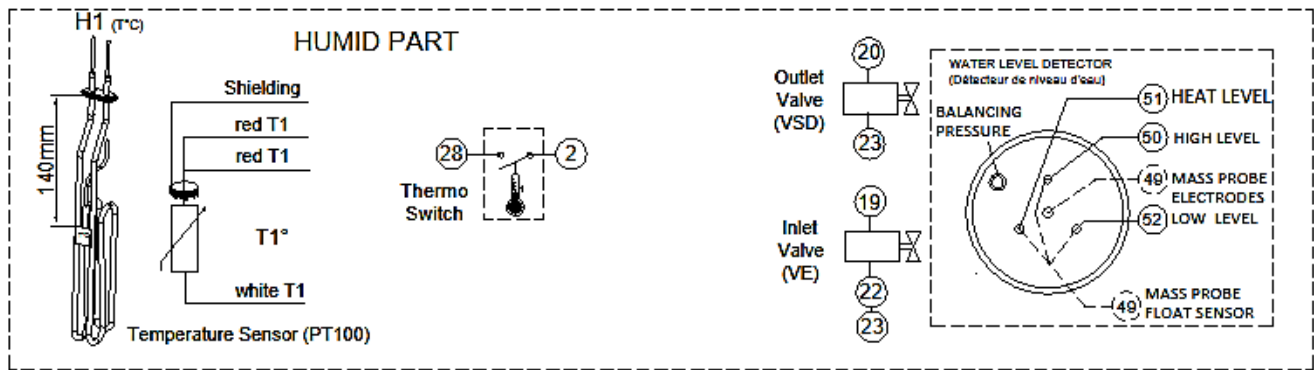

ELECTROVAP® RTH-HC

RTH-HC 5-30, Up[V] - 3x380-690V 50-60Hz

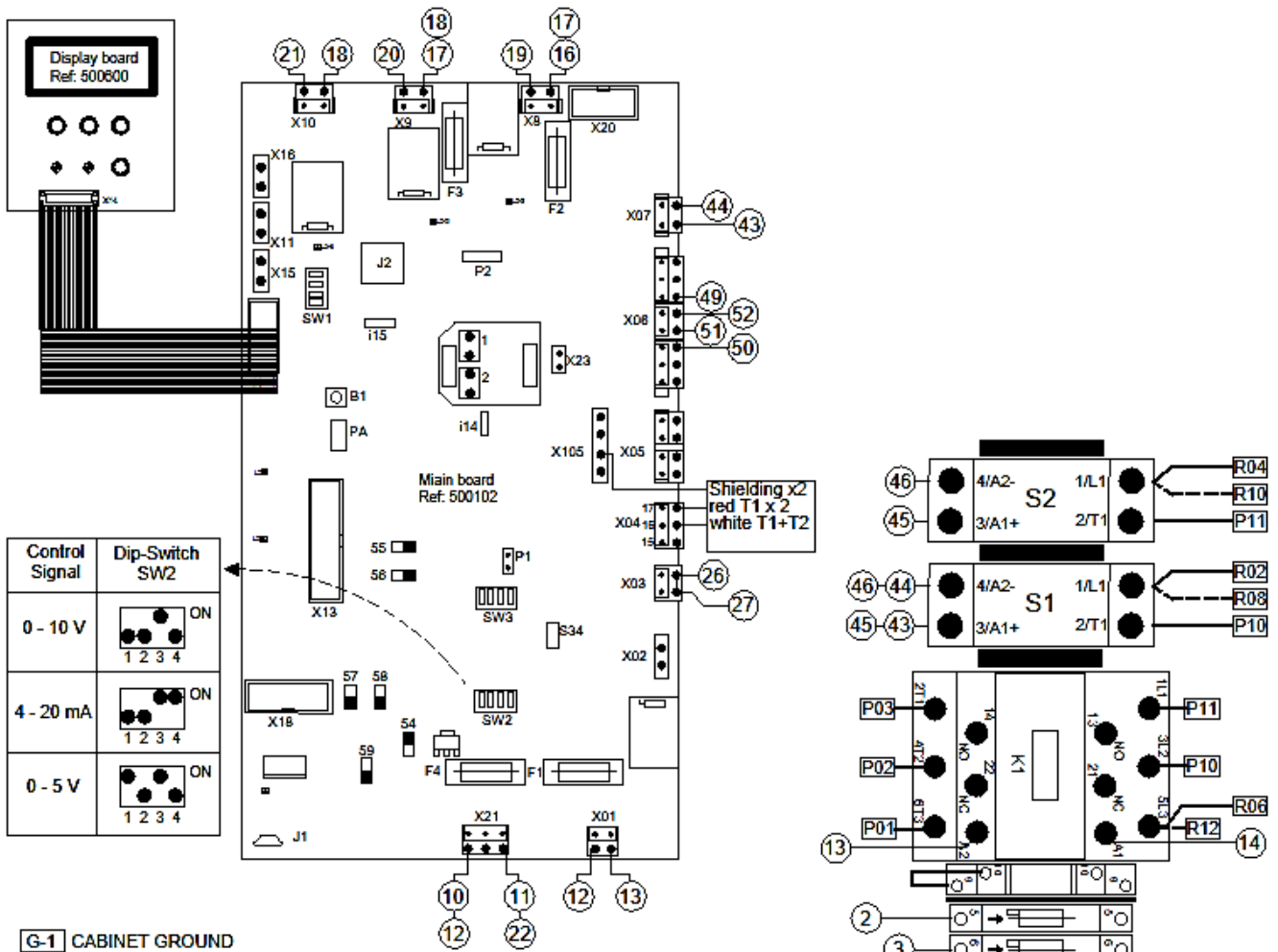
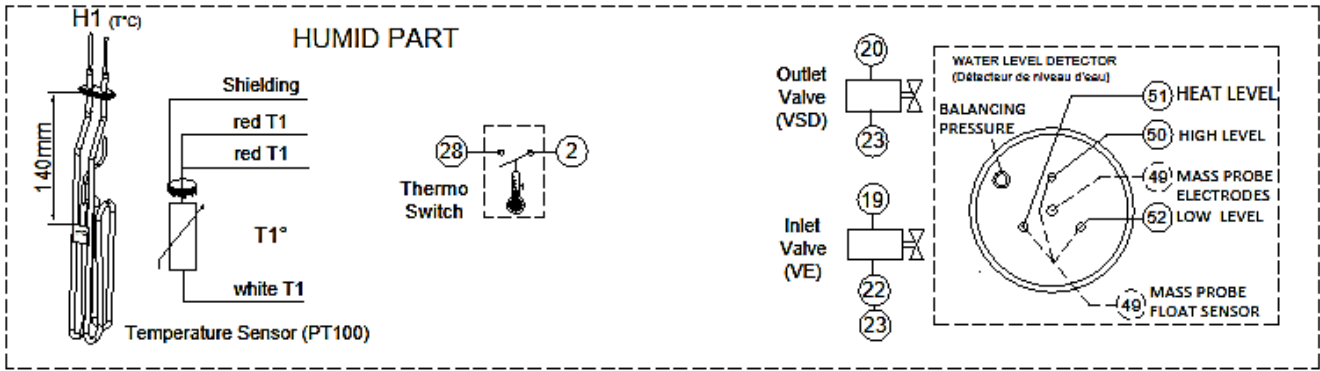

G-1 CABINET GROUND

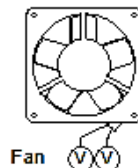
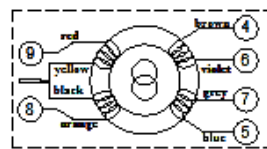
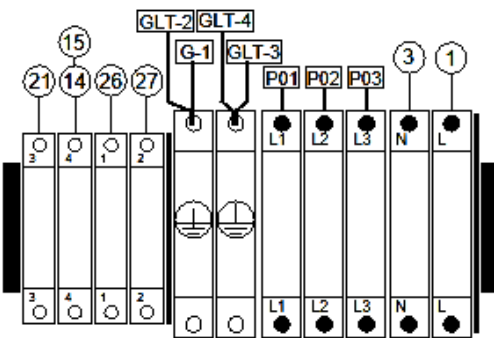

On/Off Switch

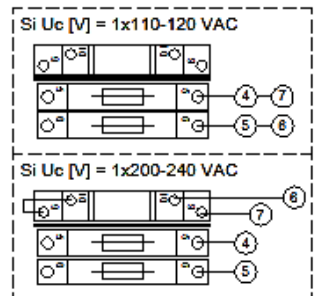
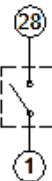

ELECTROVAP® RTH-HC

RTH-HC 40-50, Up[V] - 3x380-690V 50-60Hz

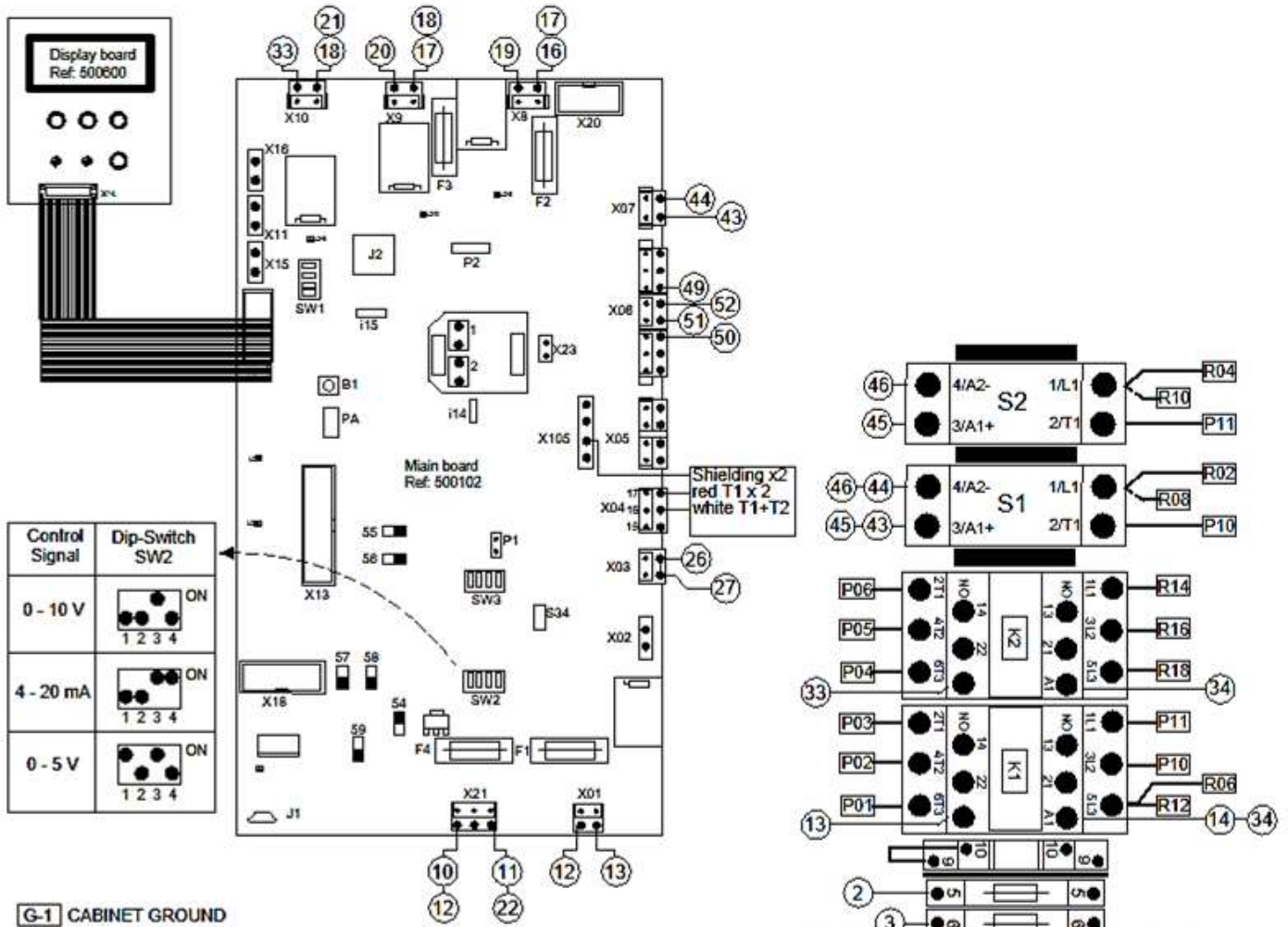
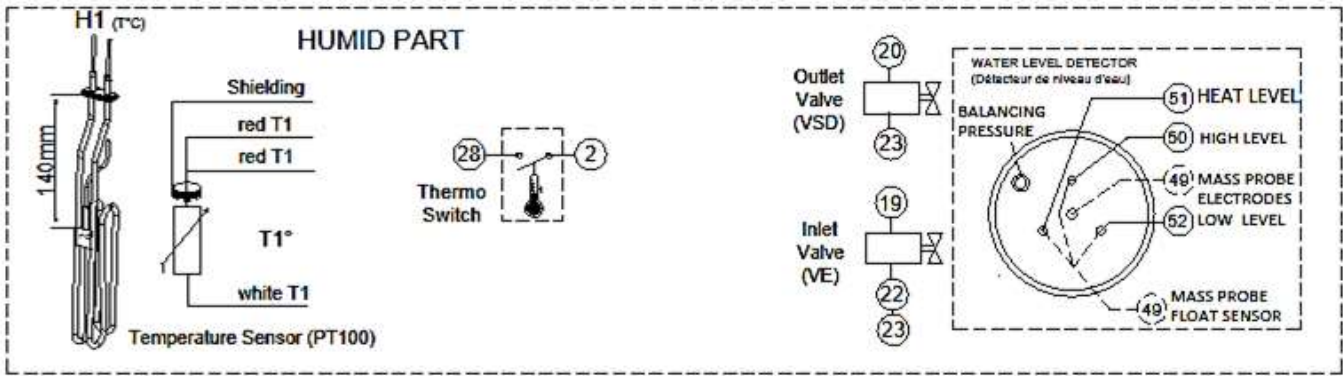

G-1 CABINET GROUND

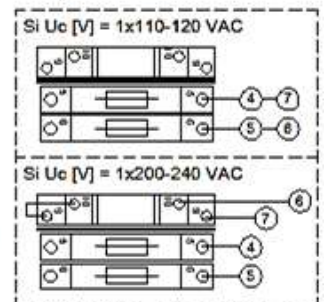
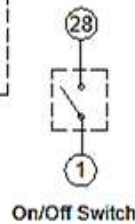
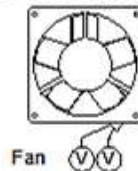
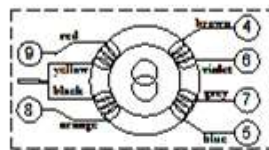
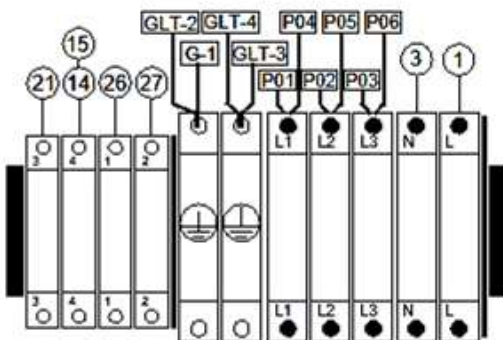

ELECTROVAP® RTH-HC

RTH-HC 60-70, Up[V] - 3x380-690V 50-60Hz

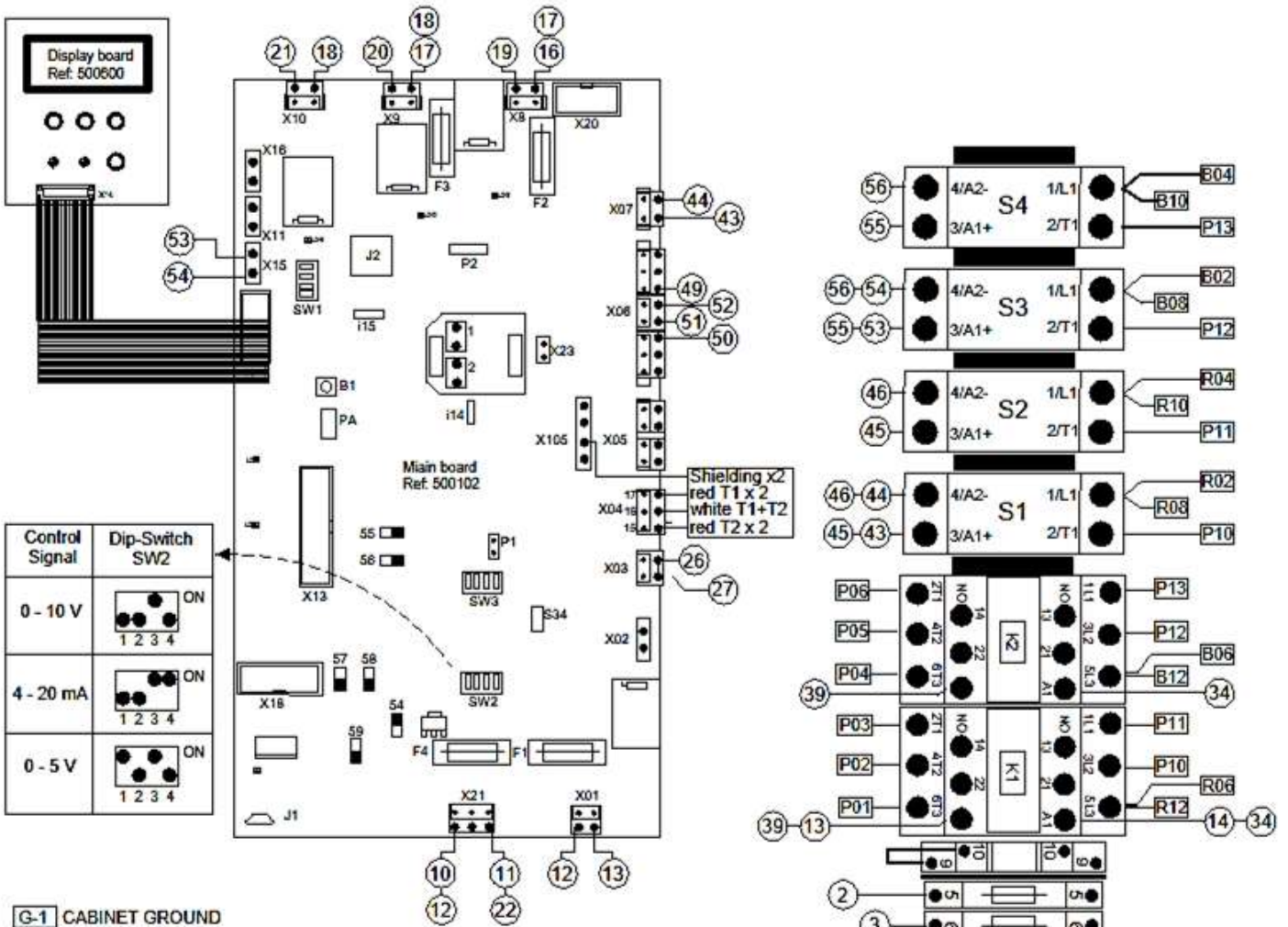
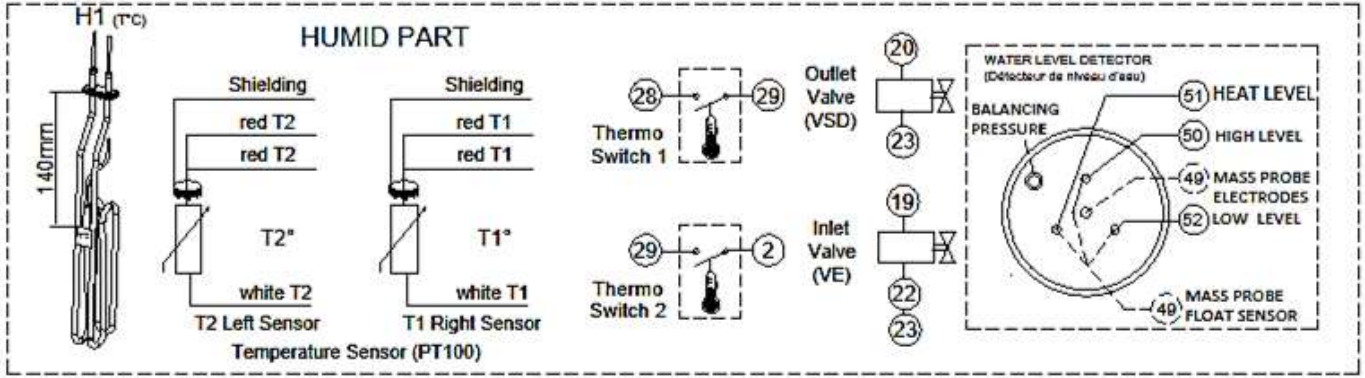

G-1 CABINET GROUND

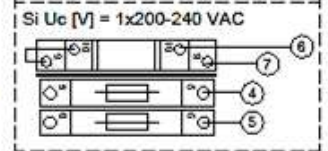
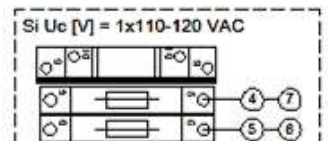
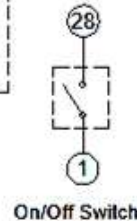
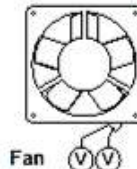
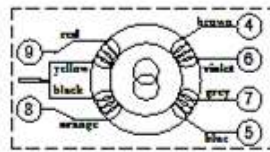
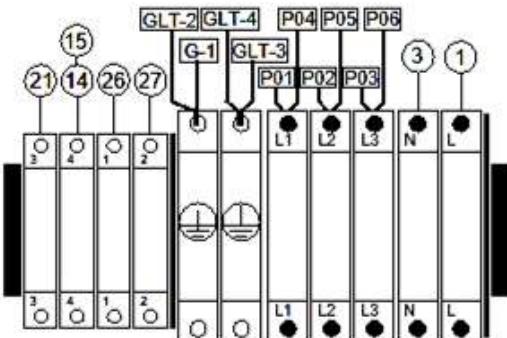

ELECTROVAP® RTH-HC

RTH-HC 80-100, Up[V] - 3x380-690V 50-60Hz

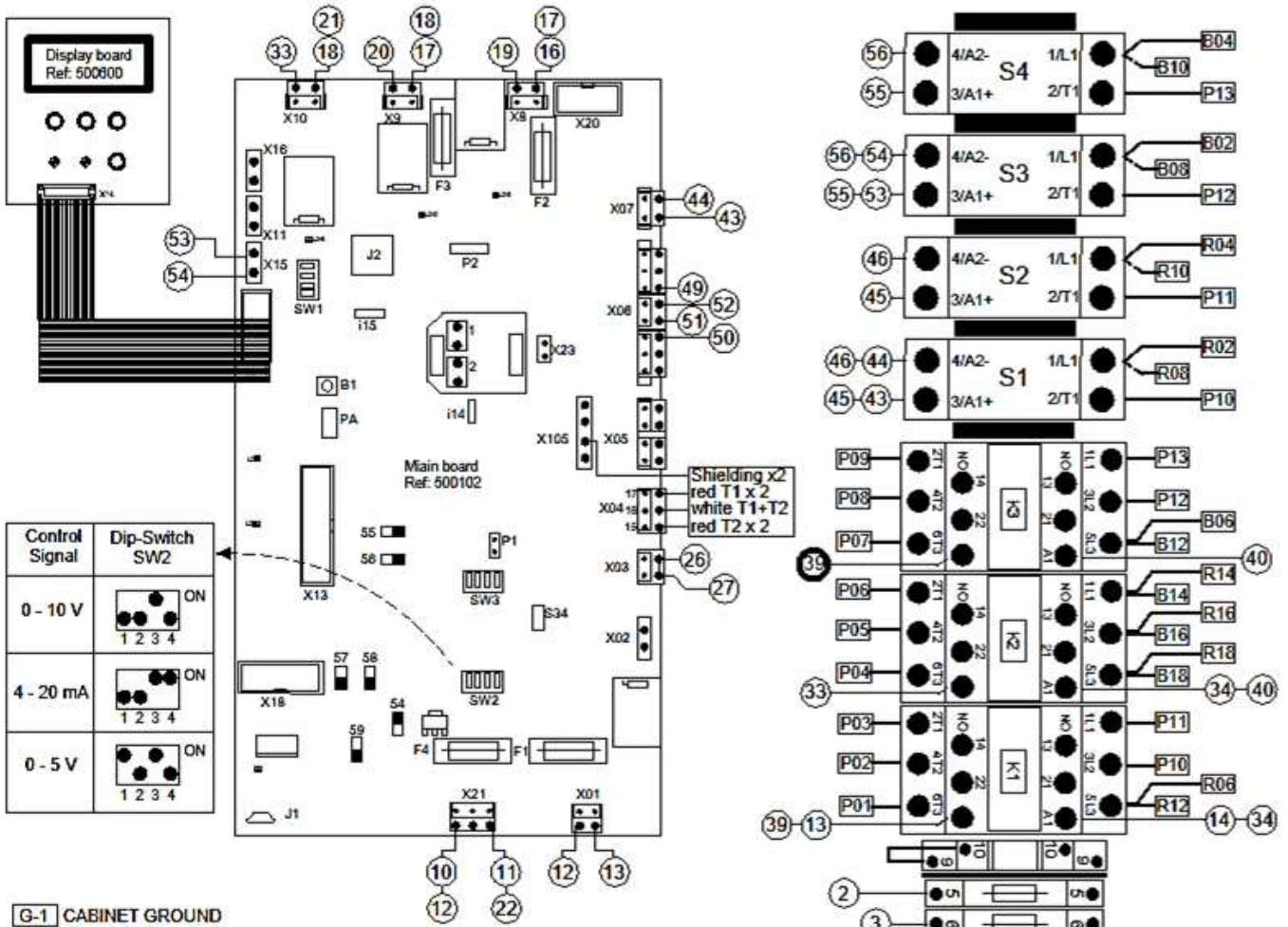
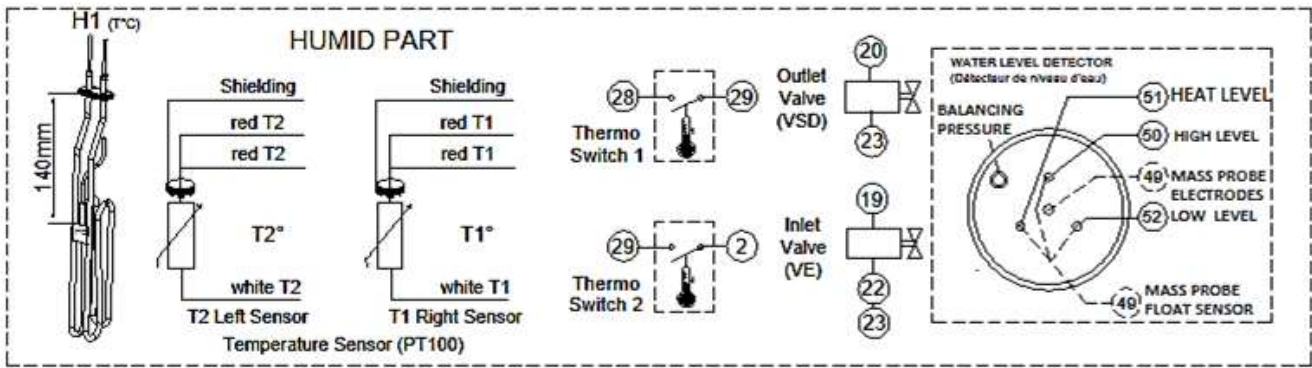

G-1 CABINET GROUND

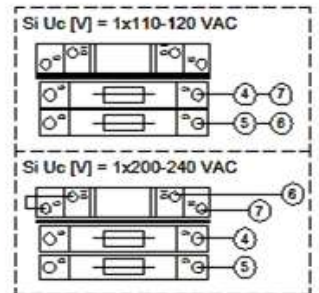
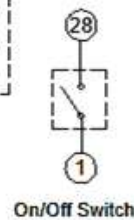
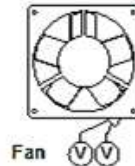
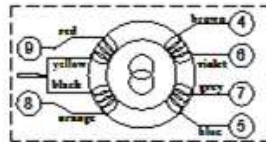
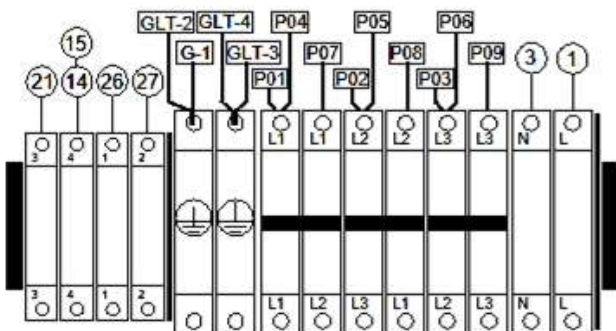

ELECTROVAP® RTH-HC

3.10 CONTROL SIGNAL CONNECTION

3.10.1 ON/OFF Control And Safety Contacts

The control must be connected using flexible shielded cable, maximum 0.75mm². This cable must not be routed with a power cable. To activate the control type, see chapter "HUMIDIFIER CONFIGURATION".

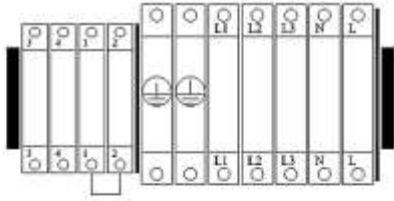

Configuration without safety contact:

⇒ Shunt between terminals 1 and 2

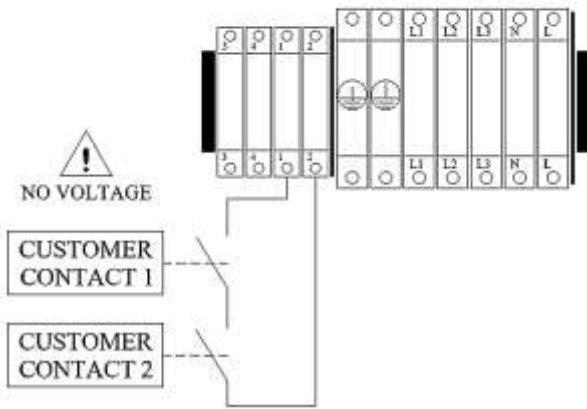

Configuration with safety contact(s):

⇒ Detector(s) to be connected in series to terminals 1 and 2

Example: Door open detection thermostat.

CTRL SIGNAL TYPE
1 STEP (ON/OFF)

3.10.2 PROPORTIONAL CONTROL

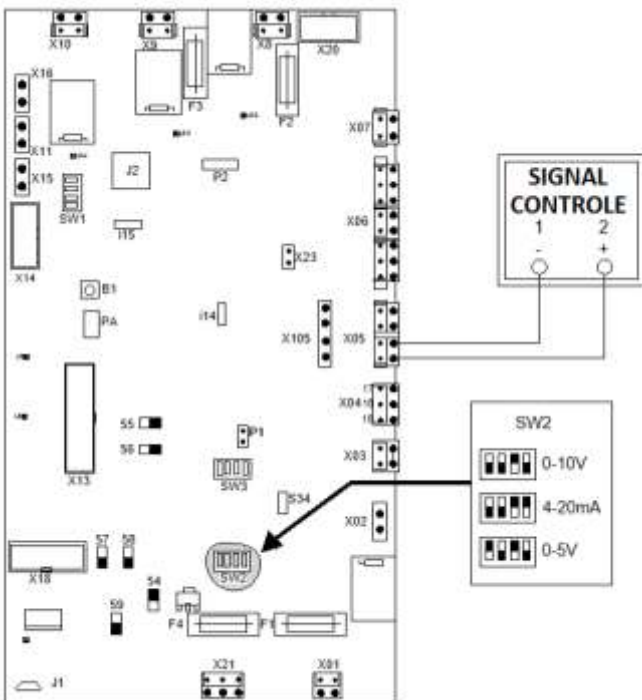

Proportional humidity controller

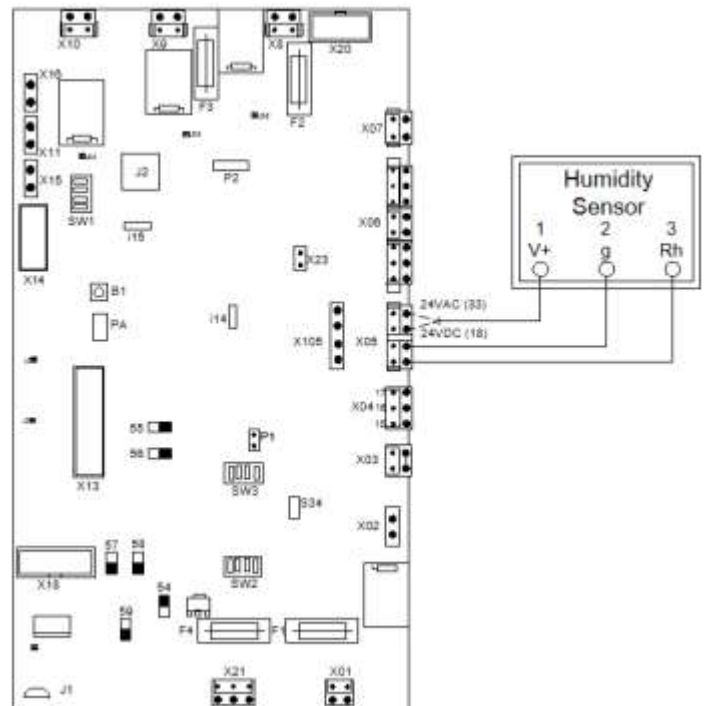

Humidity sensor with 24VDC (18,19 ,20) or 24 VAC (33,19,20) power supply

ELECTROVAP® RTH-HC

3.10.3 RS485 CONNECTION

RS485 is connected to connector J2 :

- Terminal 1: Data -
- Terminal 2: Data +
- Terminal 3: GND

Switch SW1 is used to activate or deactivate the line resistor. Depending on requirements, these resistors can be activated or deactivated (see diagram).

Fig. B 3-9.

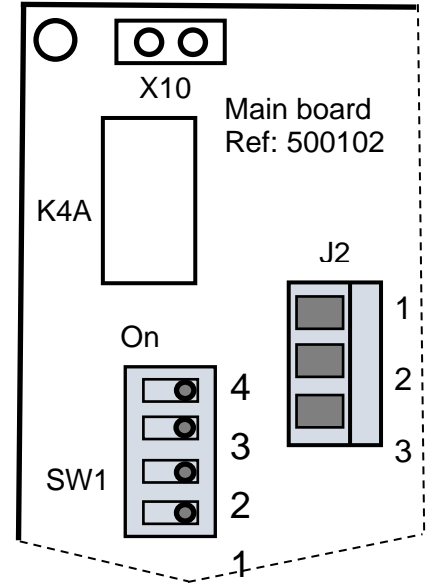
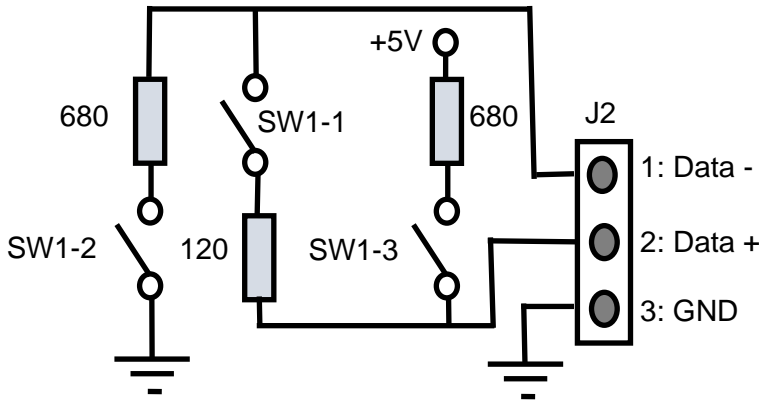

3.10.4 MODBUS RTU and BACNET MSTP Communication Parameters

	Modbus RTU	Bacnet MSTP
Communication speed	2400 / 4800 / 7200 / 9600 (default) / 14400 / 19200 / 28800 / 38400 / 57600 / 115200 / 230400	
Packet size	8 bits	
Parity bit	No	
Stop bit	2	1
Response time Before the timeout	5000ms (5sec)	
Time between 2 requests (After receiving a reply)	Min. 100ms	Standard

ELECTROVAP® RTH-HC

3.10.4.1 Standardized Bacnet Protocol Implementation Sheet

BACnet Protocol Implementation Conformance Statement

Date: 18/10/2022

Vendor Name: Armstrong International

Product Name: Armstrong Motherboard

Product Model Number: see plate.

Application Software Version: 1 Firmware Revision: 1 BACnet Protocol Revision: 19

Product Description: Mother board with integrated automate functions.

BACnet Standardized Device Profiles Supported (Annex L): BACnet Application Specific Controller (B-ASC)

BACnet Interoperability Building Blocks Supported (Annex K): Minimal required by B-ASC devices

Segmentation Capability: No segmentation

Standard Object Types Supported: Available objects are listed in the object table; each object has the minimal requirement by the standard.

The main device objectID is by default 0x02000000 + vendor ID x 1000 + ThisStationAddress, can be set in menu.

Data Link Layer Options: MS/TP master (Clause 9), baud rate(s): 9600,38400, and others (see table above).

Device Address Binding: No

Networking Options: none

Character Sets Supported: ISO 10646 (UTF-8)

For further information, please contact your dealer.

3.10.4.2 MODBUS RTU & BACNET MSTP Communication Parameters

	Modbus RTU	Bacnet MSTP
Communication speed	2400 / 4800 / 7200 / 9600 (default) / 14400 / 19200 / 28800 / 38400 / 57600 / 115200 / 230400	
Packet size	8 bits	
Parity bit	No	
Stop bit	2	1
Response time Before the timeout	5000ms (5sec)	
Time between 2 requests (After receiving a reply)	Min. 100ms	Standard

3.10.4.3 Communication Protocol for RS485 INTERFACE - MODBUS and BACNET

Modbus Register Address	Bacnet Object Class / instance # / ID (hex)			Description	Value
	Class	Instance #	ID (hex)		
10001	BI	0	00C00000	inlet valve	1 = Filling -- 0 = No filling
10002	BI	1	00C00001	drain valve	1 = drain -- 0 = no drain
10003	BI	2	00C00002	contactor K1	1 = ON -- 0 = OFF
10004	BI	3	00C00003	contactor K3	1 = ON -- 0 = OFF
10005	BI	4	00C00004	Blower pack	1 = ON -- 0 = OFF
10006	BI	5	00C00005	Service relay	1 = ON -- 0 = OFF

ELECTROVAP® RTH-HC

10007	BI	6	00C00006	Alarm relay	1 = ON -- 0 = OFF
10008	BI	7	00C00007	On/off Relay	1 = ON -- 0 = OFF
10009	BI	8	00C00008	High limite sw	1: detected -- 0: not detected
10010	BI	9	00C00009	Alarm A1 state	1 = ON -- 0 = OFF
10011	BI	10	00C0000A	Alarm A2 state	1 = ON -- 0 = OFF
10012	BI	11	00C0000B	Alarm A3 state	1 = ON -- 0 = OFF
10013	BI	12	00C0000C	Alarm A4 state	1 = ON -- 0 = OFF
10014	BI	13	00C0000D	Alarm A5 state	1 = ON -- 0 = OFF
10015	BI	14	00C0000E	Alarm A6 state	1 = ON -- 0 = OFF
10016	BI	15	00C0000F	Alarm A7 state	1 = ON -- 0 = OFF
10017	BI	16	00C00010	Alarm A8 state	1 = ON -- 0 = OFF
10018	BI	17	00C00011	Alarm A9 state	1 = ON -- 0 = OFF
10019	BI	18	00C00012	Alarm A10 state	1 = ON -- 0 = OFF
10020	BI	19	00C00013	Rh sensor error	1 = ON -- 0 = OFF
1	BO	0	01000000	On/Off BMS command	1 = ON: start required / 0 = Off: device off
2	BV	1	01400001	EOS drain statue	1 = on / 0 = off
30001	AI	0	00000000	Type unit	4: RTH-HC 5: RTH-LC 6: ERS-HC 7: ERS LC
30002	AI	1	00000001	Reg version	1
30003	AI	2	00000002	Demand	(%)
30004	AI	3	00000003	Steam output	10 x (Kg/hr)
30005	AI	4	00000004	Run status	1: Idle 2: Preheat cycle 3: Steam production 4 : Manual drain 5: Ready for use 6: Maintenance due 7: Fault 8: Aquastat on
30006	AI	5	00000005	Estimated time to service	(hours)
30007	AI	6	00000006	Production since last service (MSB)	(Kg)
30008	AI	7	00000007	Production since last service (LSB)	(Kg)
30009	AI	8	00000008	Total production (MSB)	(Kg)
30010	AI	9	00000009	Total production (LSB)	(Kg)
30011	AI	10	0000000A	Total run time (MSB)	(Hours)
30012	AI	11	0000000B	Total run time (LSB)	(Hours)
30013	AI	12	0000000C	Remaining idle time to EOS drain	(Hours)
30014	AI	13	0000000D	Control signal value	10 x V or 10 x mA or % of
30015	AI	14	0000000E	Temperature tank 1	(°C)
30016	AI	15	0000000F	Temperature tank 2	(°C)

ELECTROVAP® RTH-HC

30017	AI	16	00000010	Alarm A2 counter	A2 alarm counter
30018	AI	17	00000011	Alarm A3 counter	A3 alarm counter
30019	AI	18	00000012	Alarm A6 counter	A6 alarm counter
30020	AI	19	00000013	Alarm A7 counter	alarm counter A7
30021	AI	20	00000014	Alarm A8 counter	alarm counter A8
30022	AI	21	00000015	Partial drain timer	10 x (s)
30023	AI	22	00000016	PWM main supply	trigger value
30024	AI	23	00000017	PWM counter	meter
30026	AI	25	00000019	Max production capability	
30027	AI	26	0000001A	Number of tank	1 or 2
30028	AI	27	0000001B	Unit type ID	unit type code
30029	AI	28	0000001C	Unit voltage type	unit voltage code
30030	AI	29	0000001D	Water level status	level detected from 0 to 3
30031	AI	30	0000001E	Power consumed	(kW)
30032	AI	31	0000001F	Max power rating	(kW)
40004	AO	3	00000003	Digital Rh value or digital demand	(%) minimum = 1 and maximum = 100
40005	AV	4	00800004	Rh set point	(%) minimum = 1 and maximum = 100
40006	AV	5	00800005	EOS drain timer	(Hour) min = 1 and max = 120
40007	AV	6	00800006	Service counter	(kg / 100) from 1 to 65000
40008	AV	7	00800007	Aquastat status	1: activate -- 2: deactivate
40009	AV	8	00800008	Aquastat setpoint	min 10 max 80 (°C)
40010	AV	9	00800009	Control signal type	20 : OnOff 21: digital ctrl 22 : control digital 23 : 0-10V ctrl 24 : 1-5V ctrl 25 : 4-20mA ctrl 26 : 0-10V sensor 27 : 0-5V sensor
40012	AV	11	0080000B	Control signal adjustment	(-128 %) min 123, max 133
40014	AV	13	0080000D	Temperature 1 adjustment	(-128 %) min 123, max 135
40015	AV	14	0080000E	Temperature 2 adjustment	(-128 %) min 123, max 136
40016	AV	15	0080000F	Proportional factor of PID	typ.: 20 min. 0 max. 50
40017	AV	16	00800010	Integral factor PID	mini 0 maxi 50
40018	AV	17	00800011	Derivative factor PID	mini 0 maxi 50

ELECTROVAP® RTH-HC

3.11 WIRING DIAGRAMS

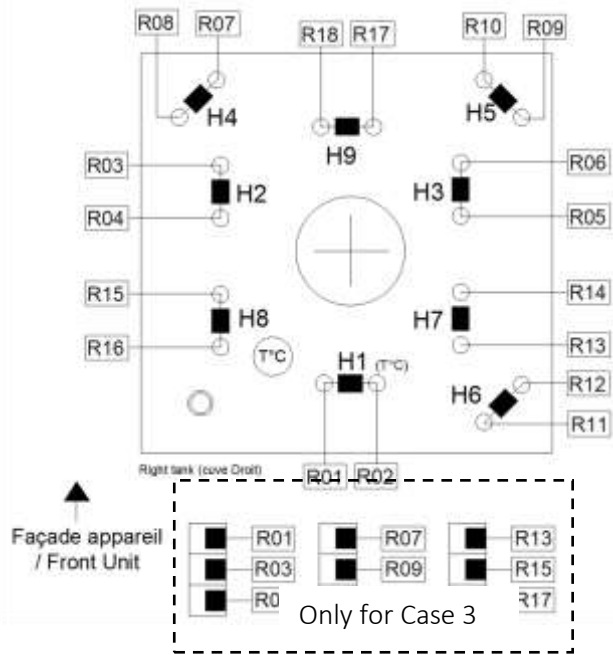

Case 3: Up[V] - 3x380-690V 50-60Hz

RTH	U [V]	H1	H2	H3	H4	H5	H6	H7	H8	H9
5	3x380	1.9K	1.9K	1.9K
	3x400	277V	277V	277V
	3x420			
7	3x380	1.9K	1.9K	1.9K
	3x400	230V	230V	230V
	3x420			
	3x440	1.9K	1.9K	1.9K
	3x460	277V	277V	277V
	3x480			
10	3x380	1.9K	1.9K	1.9K
	3x400	346V	346V	346V
	3x615			
15	3x380	1.9K	1.9K	1.9K
	3x400	230V	230V	230V
	3x420			
	3x440	4.3K	4.3K	4.3K
	3x460	277V	277V	277V
	3x480			
20	3x380	4.3K	4.3K	4.3K
	3x400	230V	230V	230V
	3x420			
30	3x380	4.3K	4.3K	4.3K	1.9K	1.9K	1.9K	.	.	.
	3x400	277V	277V	277V	277V	277V	277V	.	.	.
	3x420							.	.	.
	3x440	4.3K	4.3K	4.3K	1.9K	1.9K	1.9K	.	.	.
	3x460	277V	277V	277V	277V	277V	277V	.	.	.
	3x480							.	.	.
40	3x380	4.3K	4.3K	4.3K	1.9K	1.9K	1.9K	1.9K	1.9K	1.9K
	3x400	230V	230V	230V	230V	230V	230V	230V	230V	230V
	3x420									
50	3x380	4.3K	4.3K	4.3K	1.9K	1.9K	1.9K	1.9K	1.9K	1.9K
	3x400	277V	277V	277V	277V	277V	277V	277V	277V	277V
	3x420									
	3x440	4.3K	4.3K	4.3K	1.9K	1.9K	1.9K	1.9K	1.9K	1.9K
	3x460	277V	277V	277V	277V	277V	277V	277V	277V	277V
	3x480									

Case 1: Up[V] - 1x200-240V 50-60Hz

RTH	U [V]	H1	H2	H3
3	1x208	1.9K	■	■
	1x220	230V		
	1x230			
5	1x208	4.3K		
	1x220	230V		
	1x231			
8	1x208	4.3K	1.9K	
	1x220	230V	230V	
	1x232			

Case 2: Up[V] - 3x200-240V 50-60Hz

RTH	U [V]	H1	H2	H3	H4	H5	H6	H7	H8	H9
8	3x208	1.9K	1.9K	1.9K	■	■	■	■	■	■
	3x220	230V	230V	230V						
	3x230									
18	3x208	4.3K	4.3K	4.3K	■	■	■	■	■	■
	3x220	230V	230V	230V						
	3x231									
25	3x208	4.3K	4.3K	4.3K	1.9K	1.9K	1.9K	■	■	■
	3x220	230V	230V	230V	230V	230V	230V			
	3x232									
36	3x208	4.3K	4.3K	4.3K	4.3K	4.3K	4.3K	■	■	■
	3x220	230V	230V	230V	230V	230V	230V			
	3x233									
44	3x208	4.3K	4.3K	4.3K	4.3K	4.3K	4.3K	1.9K	1.9K	1.9K
	3x220	230V	230V	230V	230V	230V	230V	230V	230V	230V
	3x234									

ELECTROVAP® RTH-HC

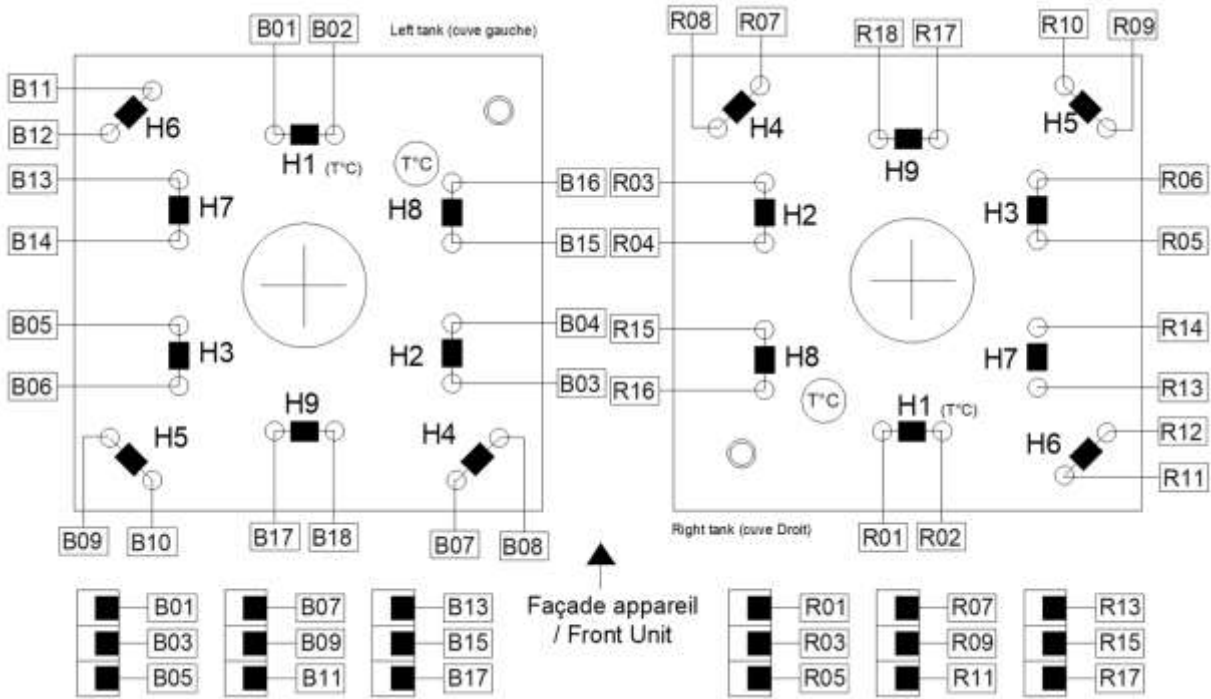

Only for Case 3

Case 2: Up[V] - 3x200-240V 50-60Hz

RTH	U [V]	RIGHT TANK									LEFT TANK								
		H1	H2	H3	H4	H5	H6	H7	H8	H9	H12	H23	H34	H45	H56	H67	H78	H89	H910
51	3x208	4.3K	4.3K	4.3K	1.9K	1.9K	1.9K	■	■	■	4.3K	4.3K	4.3K	1.9K	1.9K	1.9K	■	■	■
	3x220	230V	230V	230V	230V	230V	230V				230V	230V	230V	230V	230V	230V			
	3x230																		
62	3x208	4.3K	4.3K	4.3K	4.3K	4.3K	4.3K	■	■	■	4.3K	4.3K	4.3K	1.9K	1.9K	1.9K	■	■	■
	3x220	230V	230V	230V	230V	230V	230V				230V	230V	230V	230V	230V	230V			
	3x230																		

ELECTROVAP® RTH-HC

Case 3: Up[V] - 3x380-690V 50-60Hz

RTH	U [V]	RIGHT TANK									LEFT TANK								
		H1	H2	H3	H4	H5	H6	H7	H8	H9	H1	H2	H3	H4	H5	H6	H7	H8	H9
60	3x380	4.3K	4.3K	4.3K	4.3K	4.3K	4.3K	•	•	•	4.3K	4.3K	4.3K	4.3K	4.3K	4.3K	•	•	•
	3x400	230V	230V	230V	277V	277V	277V	•	•	•	230V	230V	230V	277V	277V	277V	•	•	•
	3x420																		
	3x440	4.3K	4.3K	4.3K	4.3K	4.3K	4.3K	•	•	•	4.3K	4.3K	4.3K	1.9K	1.9K	1.9K	•	•	•
70	3x460	277V	277V	277V	277V	277V	277V	•	•	•	277V	277V	277V	277V	277V	277V	•	•	•
	3x480																		
	3x575	4.3K	4.3K	4.3K	1.9K	1.9K	1.9K	•	•	•	4.3K	4.3K	4.3K	4.3K	4.3K	4.3K	•	•	•
	3x600	346V	346V	346V	346V	346V	346V	•	•	•	346V	346V	346V	346V	346V	346V	•	•	•
80	3x615																		
	3x690	4.3K	4.3K	4.3K	1.9K	1.9K	1.9K	•	•	•	4.3K	4.3K	4.3K	4.3K	4.3K	4.3K	•	•	•
		398V	398V	398V	398V	398V	398V	•	•	•	398V	398V	398V	398V	398V	398V	•	•	•
90	3x380	4.3K	4.3K	4.3K	4.3K	4.3K	1.9K	1.9K	1.9K	4.3K	4.3K	4.3K	4.3K	4.3K	4.3K	1.9K	1.9K	1.9K	
	3x400	230V	230V	230V	230V	230V	230V	230V	230V	230V	230V	230V	230V	230V	230V	230V	230V	230V	
	3x420																		
	3x440	4.3K	4.3K	4.3K	4.3K	4.3K	4.3K	4.3K	4.3K	4.3K	4.3K	4.3K	4.3K	4.3K	4.3K	4.3K	1.9K	1.9K	1.9K
100	3x460	277V	277V	277V	277V	277V	277V	277V	277V	277V	277V	277V	277V	277V	277V	277V	277V	277V	
	3x480																		
	3x575	4.3K	4.3K	4.3K	4.3K	4.3K	4.3K	4.3K	4.3K	4.3K	4.3K	4.3K	4.3K	4.3K	4.3K	4.3K	1.9K	1.9K	1.9K
	3x600	346V	346V	346V	346V	346V	346V	346V	346V	346V	346V	346V	346V	346V	346V	346V	346V	346V	346V
100	3x615																		
	3x690	4.3K	4.3K	4.3K	4.3K	4.3K	4.3K	4.3K	4.3K	4.3K	4.3K	4.3K	4.3K	4.3K	4.3K	1.9K	1.9K	1.9K	
		398V	398V	398V	398V	398V	398V	398V	398V	398V	398V	398V	398V	398V	398V	398V	398V	398V	

ELECTROVAP® RTH-HC

3.12 WATER LEVEL SENSOR WIRING

- 49 : Reference (if electrode sensor)
- 50: High level
- 51: Intermediate level
- 52: Low level

Fig. C 3-12. FLOAT LEVEL SWITCH

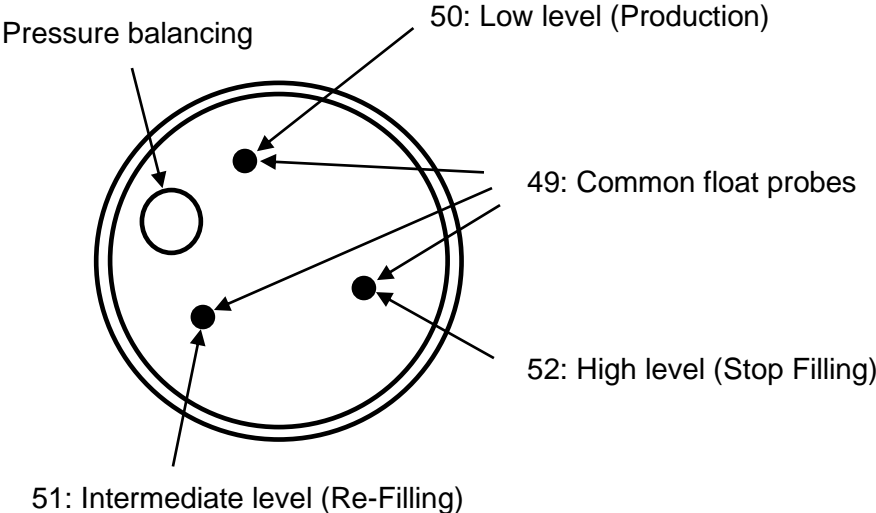
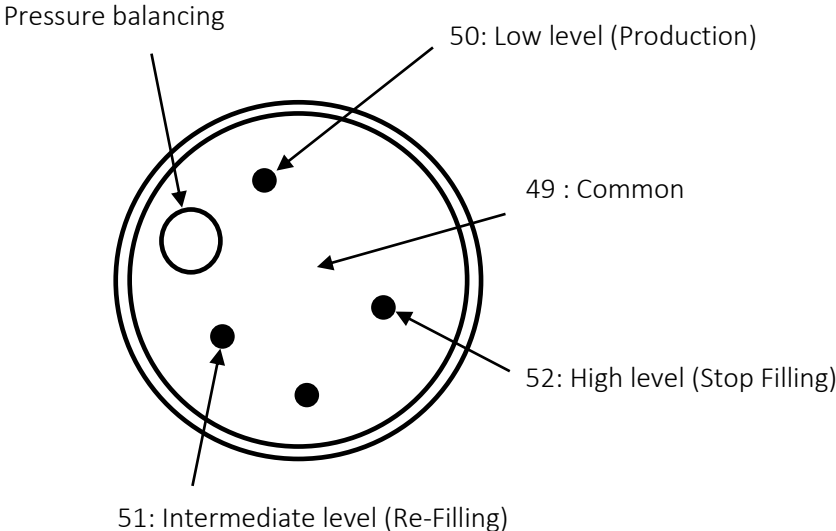

Fig. D 3-12. (OPTION) ELECTRODE LEVEL SWITCH



4. COMMISSIONING



Before commissioning your appliance, please check that your installation complies with the manufacturer's technical specifications. Screw back all electrical power cable terminals.

Marker 1: Validation & change menu button

Marker 2: Scroll up menu

Marker 3: Scroll down menu

Marker 4: Manual drain button for maintenance

Marker 5: LED = Steam production indication

- Open the main water supply valve.
- Switch off the device (power and control voltages).

- Set I/O (on/off) switch to I.

- If the device requires a commissioning code, please note the serial number on the nameplate and contact your sales representative to obtain the code.

- Enter your three-digit code as follows:

Press one of the 1, 2, 3 buttons and the display shows 0XX, with the zero flashing, so you can change it by pressing 2 or 3.

Once you've reached the required digit, confirm it by pressing 1 and your second digit will flash.

Repeat the previous two operations to display the last two digits.

Very important: don't forget to validate the last digit.

- Enter water quality in the menu displayed.
- The machine is ready to meet any production demand.
- When steam is produced, the LED (5) lights up.

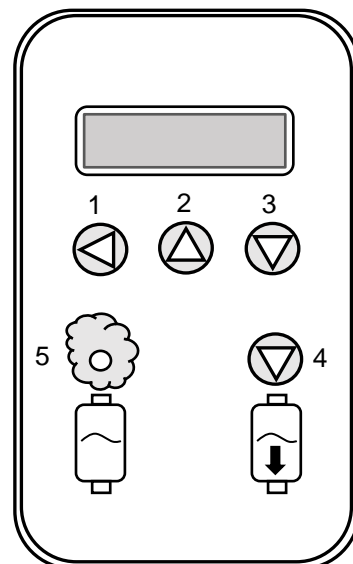
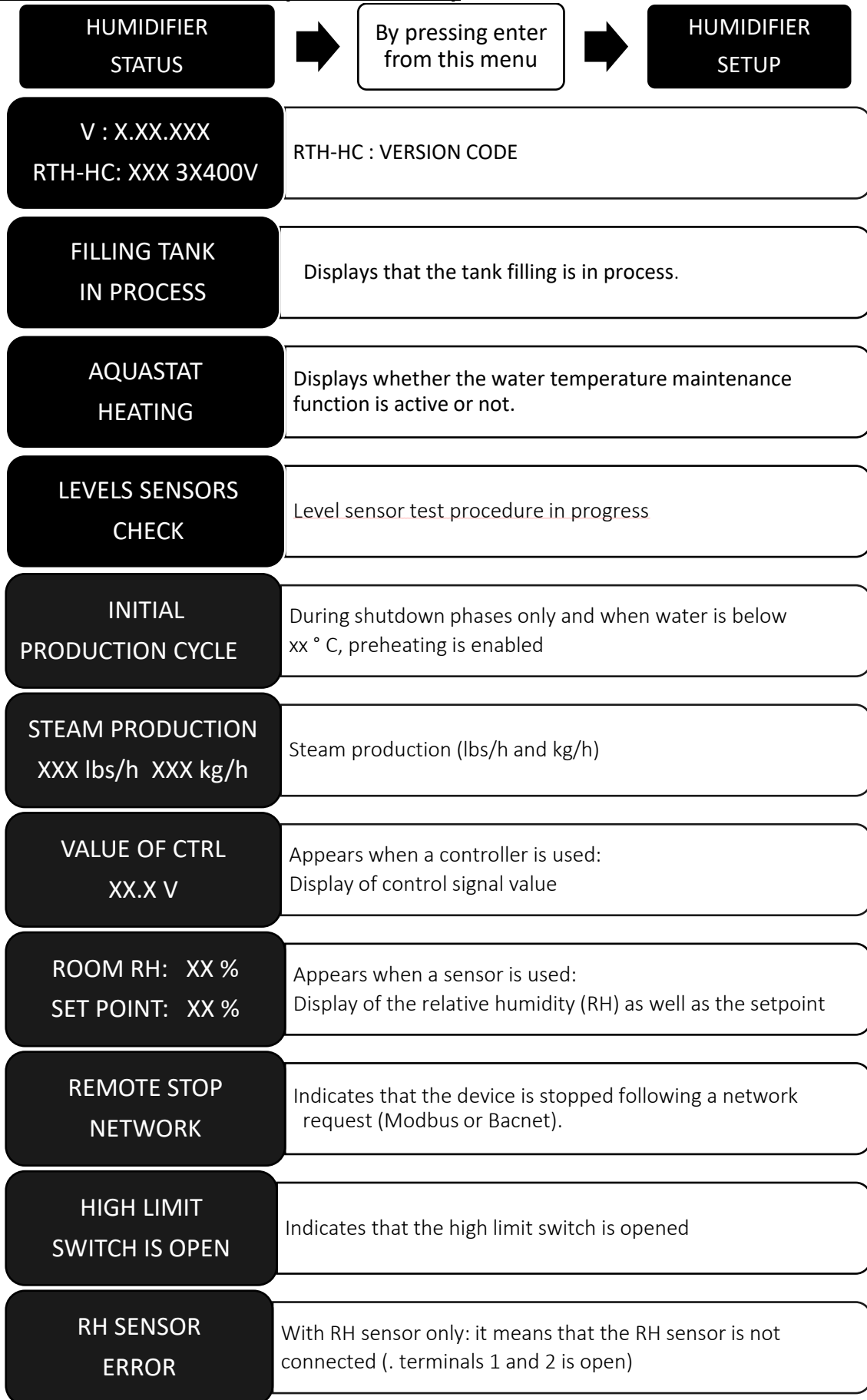

Fig. 4 Humidifier display

ELECTROVAP® RTH-HC

5. SYSTEM MANAGEMENT

5.1 INFORMATION MENU (READ-ONLY)



ELECTROVAP® RTH-HC

STEAM DEMAND XXX %	Display of steam demand in %.
TANK TEMPERATURE XXX °C XXX °F	Water temperature (RTH 1 tank)
T: L XXX °C XXX °F R XXX °C XXX °F	Water temperature in both tanks (RTH 2 tanks) L: Left tank, R: Right tank
TIME REMAINING TO EOS XXXX hrs	Remaining time without demand before end of season
PRODUCTION TO EOL XXXXXX h	Maintenance counter, at 0 h maintenance is due
PRODUCTION TO EOL XXXX kg	Maintenance counter, at 0 kg maintenance is due
TOTAL RUN TIME XXXXX h	Time meter
TOTAL PRODUCTION XXXXX kgs	Produced kg counter
POWER CONSUMED XXX kW	Displays electrical power consumption
MAX POWER RATE XXX kW	Maximum power

ELECTROVAP® RTH-HC

5.2 SETUP MENU

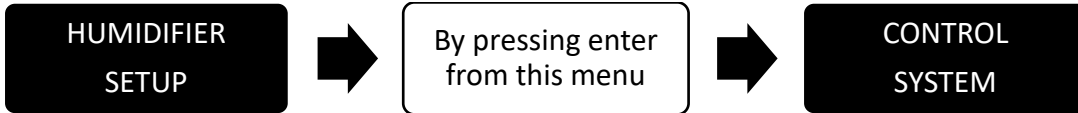

PROD. LIMITATION XXX %	Adjusting of Steam Production 1 STEP - On / Off: 20 % > Limit > 100 % Other control: 50 % > Limit > 100 %
CTRL SIGNAL TYPE XXXX XXX	Control signal configuration: 1 STEP ON/OFF, 4-20mA, 0-5V, 0-10V, 2-10V, DIGITAL CTRL, DIGITAL PROBE
SET POINT XX % RH	Display when a RH sensor is used Setting the set point (1 - 99 % Rh)
PID SETTINGS P: XX I: XX D: XX	Setting of PID (0 to 50: P - I - D)
END OF SEASON DRAIN? XXX	Setting: End Of Season (EOS) Enable or disable of drain system (OFF or ON)
EOS TIMER SETTING: XX Hrs	Timeout EOS (1 to 72 hrs)
AQUASTAT SETTING XX	Aquastat function keeps water hot during steam production shutdowns
AQUASTAT SP XX °F XX °C	Water holding temperature setting during shutdowns 65°C > °C > 95°C or 149 °F > °F > 203°F
WATER TYPE USED XXXX XXXX	Water type setting: "TAP WATER", "DI WATER", "PARTIAL DI WATER", "SOFTENED WATER"
EOL SETTING XXXXXX KG	End Of Life setting: 100>Kg>20000

ELECTROVAP® RTH-HC

5.3 CONTROL SYSTEM MENU

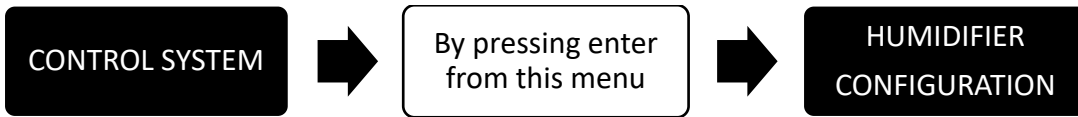

K FV DV LV1 X X X X	K: Contactor (0: no production / 1: production) FV: Filling Valve, DV: Drain valve (0: closed / 1: open) LV: Level (0: low, filling / 1: production, filling, 2: intermittent filling, 3: high, stop filling)
NS HLS CTRL D% X X X X	NS: Network status HLS: High Limit Switch 0: open / 1: closed CTRL: Control Signal D%: Steam demand 0 à 100
TX COM 1	Communication port TX
RX COM 1	Communication port RX
A1: L XXX °C XXX°F X R XXX°C XXX°F	Alarm Status A1 0: no fault/ 1: fault Water temperature for right/left tank (NC displayed if the sensor is not connected)
A2 LV VF TIMER X X	Alarm Status A2 0: no fault/ 1: fault LV: Level 0 / 1 / 2 / 3 FV : Filling Valve 0 (closed) / 1 (open)
A3 LV FV TIMER X X	Alarm Status A3 0: no fault/ 1: fault LV: Level 0 / 1 / 2 / 3 FV : Filling Valve 0 (closed) / 1 (open)
A4: L XXX °C XXX°F X R XXX°C XXX°F	Alarm Status A4 0: no fault/ 1: fault Water temperature for right/left tank (NC displayed if the sensor is not connected)
A6 LV DV TIMER X X	Alarm Status A6 0: no fault/ 1: fault LV: Level 0 / 1 / 2 / 3 DV : Drain Valve 0 (closed) / 1 (open)
A7: LV D% TIMER X X XXX XXXX	Alarm Status A7 0: no fault/ 1: fault LV: Level 0 / 1 / 2 / 3 D%: Demand % TIMER: Timeout

ELECTROVAP® RTH-HC

A8	LV	FV	TIMER	Alarm Status A8	0: no fault/ 1: fault
X	X	X	X	LV: Level	0 / 1 / 2 / 3
				FV : Filling Valve	0 (closed) / 1 (open)
				TIMER: Timeout	
A9	LV	DV	TIMER	Alarm Status A9	0: no fault/ 1: fault
X	X	X	X	LV: Level	0 / 1 / 2 / 3
				DV : Drain Valve	0 (closed) / 1 (open)
				TIMER: Timeout	
A10	LV	FV	TIMER	Alarm Status A10	0: no fault/ 1: fault
X	X	X	X	LV: Level	0 / 1 / 2 / 3
				FV : Filling Valve	0 (closed) / 1 (open))
				TIMER: Timeout	

ELECTROVAP® RTH-HC

5.4 MENU: HUMIDIFIER CONFIGURATION

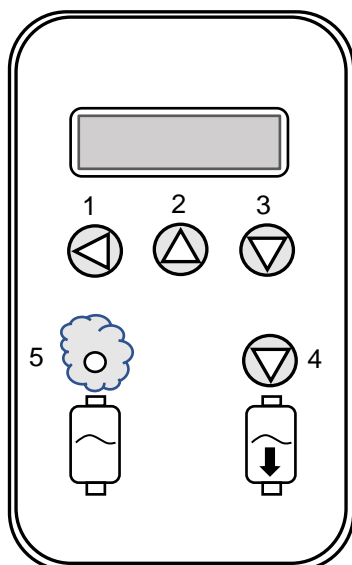

How to enter your access code :

- Press key 1, the first cross flashes
- Press the 2 or 3 key to change the number.
- Once you've reached the desired digit of your code, press 1 to confirm; the second cross will flash.
- Proceed in the same way for the following digits, and don't forget to validate your code by pressing 1.

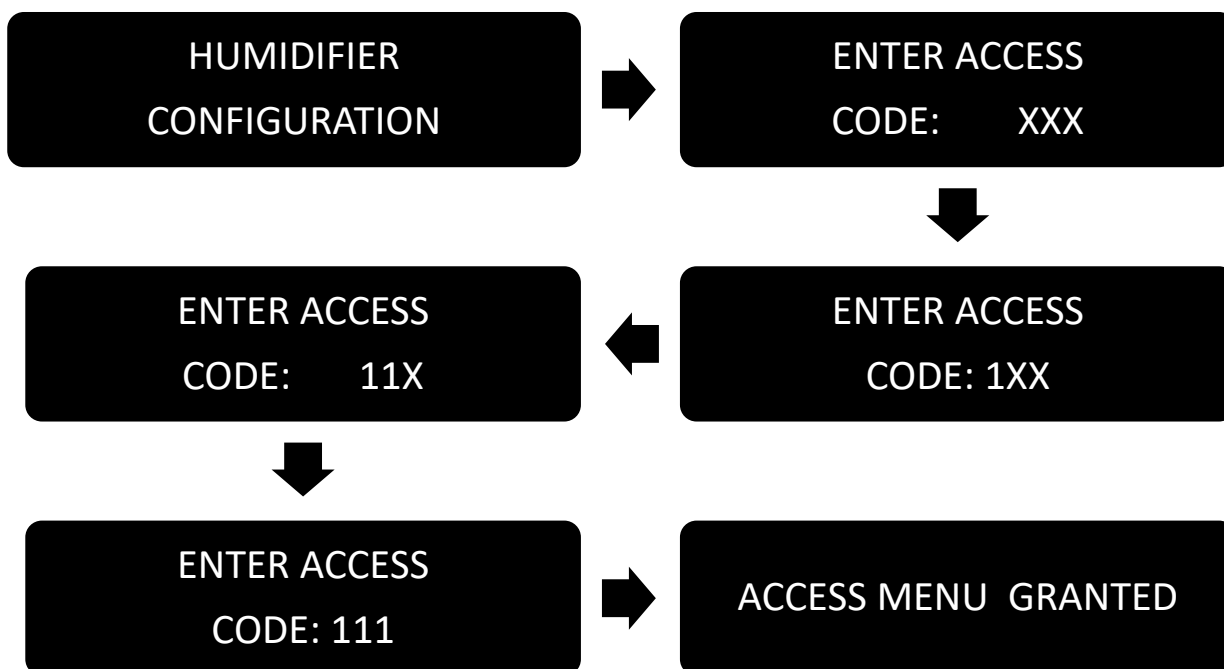

ELECTROVAP® RTH-HC

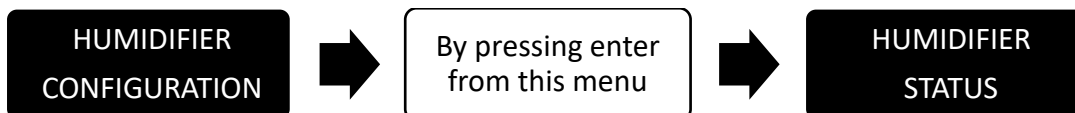

LANGUAGE XXXXXXXX	Values : FRANCAIS , ENGLISH, etc...
CHANGE UNIT TYPE RTH HC XXX	Model: RTH HC 8 , 10, etc. ...(see range)
CHANGE VOLTAGE Xxxxx V	Selection of power heating: 2x200/2x220/2x230/3x200/3x208/3x220/3x230/3x380/3x400/3x415/3x440/3x460/3x480/3x575/3x600/3x690
TOTAL GROUP PROD.: XX KG	For Master / Slave control only: adjusts the total production of the RTH group
DRAIN LOGIC xxxxxx	Allows to choose the drain logic (CYCLIC BASED or TIMED BASED)
CYCLE DRAIN DURATION: Xxxx	Setting of drain duration in seconds
DRAIN FREQUENCY: EVERY XX CYCLES	Frequency of drain system IF TIMED BASED: 1 - 255 min IF CYCLIC BASED: 1 - 10 cycles
COOLING TYPE: Xxxxxxx	Type of tank cooling ECO COOLING: Natural cooling FAST COOLING: by adding cold water
SELF-CHECKING STATUS XXX	Startup of self-checking system ("YES" or "NO")
CALIBRATION FOR CTRL SIGNAL XXXX%	Calibration of control signal (-10% at +10%)

ELECTROVAP® RTH-HC

CALIBRATION FOR T° RIGHT XXXX%	Calibration of the tank temperature sensor (-15% at +15%). For the RTH 2 tanks: right temperature.
CALIBRATION FOR T° LEFT XXXX%	Only for RTH with 2 tanks only: Calibration left temperature (-15% at +15%).
CURRENT TIME YYYY/MM/DD HH:MM	Setting current time (lost when power is off) “year/Month/day Hour/Minute”
MFGR TEST DATE MM / YYYY	Factory testing date “Month, year” (read only)
NETWORK UNIT ID XXX	Address unit network 1 < ID < 254
COM SPEED XXXX00 bs	Communication network speed for RS485 2400 < speed < 230400
COM PROTOCOL XXXXXXXX	Network connected: “MODBUS RTU” or “BACNET MS/TP”

ELECTROVAP® RTH-HC

5.5 MAINTENANCE ALERTS

**M1: CHECKING 50hr
DUE**

This message appears 50 hours after the 1st start-up.
Check that all electrical and hydraulic connections (steam hose, drainage system, water supply, etc.) are tight. The unit is not stopped.

**M2: SERVICE DUE
TO DO**

Means that maintenance must be carried out.
The unit is not stopped.

**M3: SERVICE OVER
DUE: DRAINING**

- This message appears if 100 hours have elapsed between the appearance of message M2 and M3 and no maintenance has been carried out.

**M3: SERVICE OVER
DUE: COOLING**

- The unit is then stopped and follows a procedure:

1. Drain tank
2. Cylinder cooling
3. Ready for maintenance

**M3: SERVICE OVER
DUE: STOP UNIT**

**MANUAL DRAIN
IN PROCESS**

This message is displayed once after pressing the manual drain button. The drain is activated..

**COOLING CYCLE
IN PROCESS**

This means that the manual drain is complete, and you must wait for the tank temperature to go down before servicing..

DO MAINTENANCE

The tank is empty and cooled, maintenance can be done.
See technical manual.



TO RESET THE ABOVE MESSAGES, FOLLOW THIS PROCEDURE:

- Press the manual drain button (4) on the unit.
- Press the down arrow button (3) for at least 5 seconds.

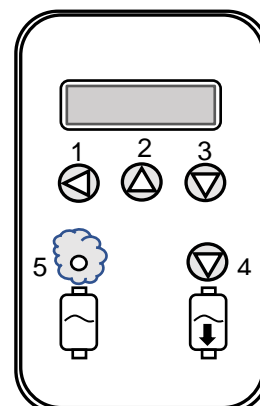

5.6 DEFAULT MESSAGES

A1: TANK TEMP.
OVER-HEAT

Meaning:

The temperature inside the tank is too high: > 110°C. Heating elements no longer fully immersed.

In this case :

When this message appears, the tank is drained, the general fault contact is activated and the unit is then shut down.

Possible causes and solutions:

1. **Poor water supply to the tank.** A block of limescale is blocking the water inlet to the tank. The tank must be cleaned.
2. **Water level sensor malfunction.** Check electrical connection between level switch and main board (see control wiring diagrams). Check float integrity and detector cleanliness.
3. **Faulty temperature sensor or need to recalibrate.** If this message appears when the tank is cold, test the temperature sensor (PT100) and replace if necessary, then contact your agent to recalibrate.
4. **Problem with water quality.** Foam is forming in the tank; increase duration of purges. From the "HUMIDIFER CONFIGURATION" menu, find the "DRAIN LOGIC" menu and activate the "TIMED BASED" mode. Also check softener regeneration times when using softened water.
5. **Electronic problem.** In case of malfunction, replace the main board. Next, check that there is no steam rising or water leaking into the electrical compartment.

ELECTROVAP® RTH-HC

A2: TANK FILLING TOO LONG

Meaning:

The tank is not being filled correctly. The water level is below the low level (maximum filling time before alarm: 20 min).

A3: FILL VAPORIZATION AREA

Meaning:

No filling between low and intermediate level.

A8: PROBLEM RE-FILL ISSUE

Meaning:

No filling between intermediate and high levels.

In this case :

When this message appears, the tank is drained, the general fault contact is activated and the unit is then shut down.

Possible causes and solutions:

1. **Check water supply.** The pressure should be constant, between 2 and 8 bar. If in doubt, install a pressure regulator set at 2 bar on the supply pipe. Also check the condition of the water inlet valve, the electrical connection and the F2 (2A) fuse. Replace the valve and fuse if they are faulty.
2. **Check that condensate is properly drained.** Condensate must be drained off, otherwise it accumulates in the ramp, causing water to splash into the unit and pressure to build up in the tank, preventing the unit from being filled.
3. **Check that the drain valve closes properly.** A piece of limestone can block the valve's flap closure and cause a leak, preventing the unit from being filled correctly.
4. **Electronics.** Replace the main board and check that there is no steam rising or water leaking into the electrical compartment.

ELECTROVAP® RTH-HC

A4: TEMP. SENSOR DISCONNECTED

Meaning:

Temperature sensor is either faulty or disconnected.

In this case :

When this message appears, the general fault contact is activated and the unit is stopped.

Possible causes and solutions:

1. **Check electrical connections.** The temperature sensor must be connected to the main board to connector X04 terminals 17 (2 red wires) and 16 (white wire). The ground wire is connected to connector X105 on terminal 49.

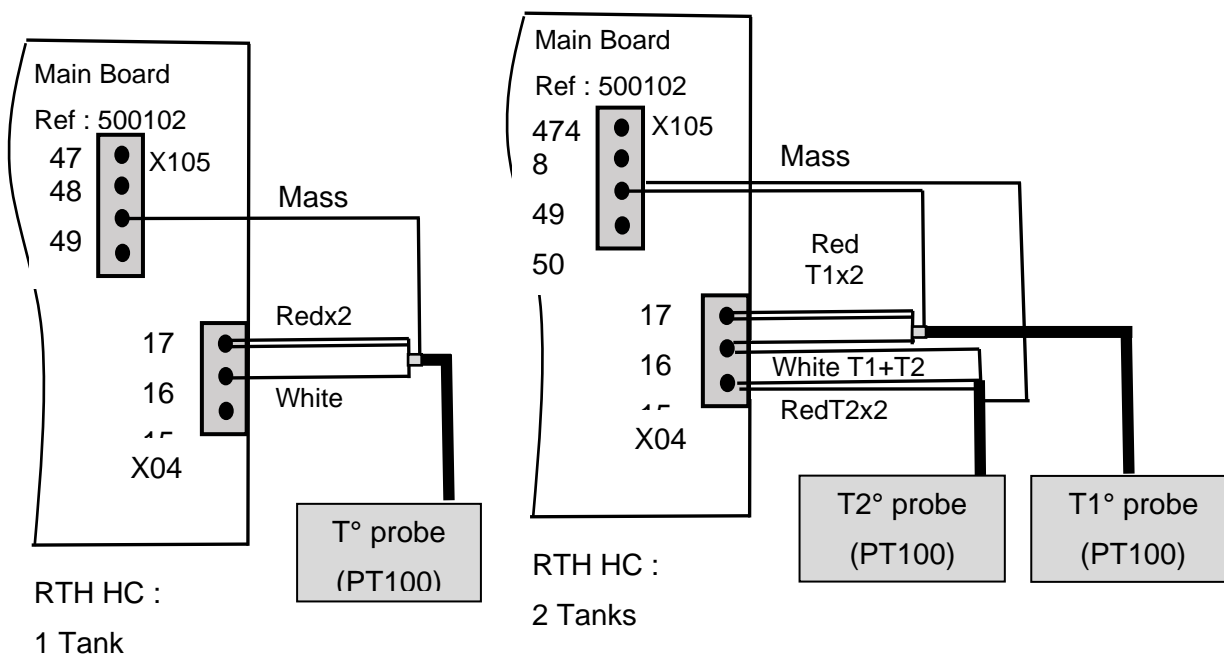

2. **Defective temperature sensor.** Disconnect temperature sensor from connector X04. Using a multimeter, measure the ohmic value of the PT100 at ambient temperature, and compare this value with the PT100 ohmic value table.
If the value is different, the sensor is faulty, replace the sensor.
3. **Electronic problem.** Replace the main board and check that there is no steam rising or water leaking into the electrical compartment.

ELECTROVAP® RTH-HC

A6: HIGH LEVEL BLOCKED

Meaning:

The high level is continuously activated (time to detection: 14 minutes).

In this case :

When this message appears, the general fault contact is activated and the unit is stopped.

Possible causes and solutions:

1. **Problem with level switch.** Check electrical connection between level switch and main board (see control wiring diagrams). Check float integrity and detector cleanliness.
2. **Electronic problem.** Replace the main board and check that there is no steam rising or water leaking into the electrical compartment.

A7: VAPORIZATION TOO LONG

Meaning:

Steam production is insufficient.

In this case:

When this message appears, the general fault contact is activated and the unit is stopped.

Possible causes and solutions:

1. **Incorrect power supply.** Using a voltmeter, check terminals L1, L2 and L3 for power supply voltage (Vac) to the heating resistors. If the power voltages are not correct, check the supply circuit down to each resistor and replace any faulty components.
2. **Continuous water supply.** Check water supply pressure ($2 > P \text{ (bar)} > 8$), replace solenoid filling valve if necessary.
3. **Problem with water level sensor.** Check electrical connection between level switch and main board (see control wiring diagrams). Check float integrity and detector cleanliness.
4. **Electronic problem.** Replace the main board and check that there is no steam rising or water leaking into the electrical compartment.

A9: COMPLETE
DRAIN TOO LONG

Meaning:
Water drainage problem.

In this case :
When this message appears, the general fault contact is activated and the unit is stopped.

Possible causes and solutions:

1. **Drain circuit is clogged.** Press "MANUAL DRAIN" button, and check water flow. Perform the following maintenance: tank (page 58), drain valve (page 59), level sensor (page 60). Also check that there are no obstructions in the drain pipe.
2. **Fuse F3 out of order.** Replace fuse F3, located on main board, and drain valve.
5. **Electronic problem.** Replace the main board and check that there is no steam rising or water leaking into the electrical compartment.

A10-AX : LEVEL
CHECK FAILED

Meaning:
Problem with water level sensor or drain system.

In this case :
When this message appears, the tank is drained, the general fault contact is activated and the unit is then shut down.

Possible causes and solutions:

1. **A float level switch is blocked.** Check and clean water level sensor.
2. **The drain valve is out of order and/or fuse F3 is blown.** Replace fuse F3, located on the main board, and the drain valve.
3. **drain circuit blocked.** Clean drain circuit, tank, drain valve, drain hose, recovery water tank (optional).
4. **electronics problem.** Replace the main board and check that there is no steam or water flowing into the electrical compartment.

ELECTROVAP® RTH-HC

Black screen: Power on/off of display and device after possible overheating



Meaning:

The "Overheating" problem is detected by the high temperature sensor (installed on the tank cover).

In this case :

When this display is off, the control voltage is cut off by the high-temperature detector and the unit is switched off.

Possible causes and solutions:

- 1 **Overheating in the tank has been detected.** Check water level sensor, cables and heating elements.
Replace worn float sensor and/or heating element, tank gasket and temperature sensor.

Once the problem has been solved, press the high temperature sensor reset button on the tank lid.

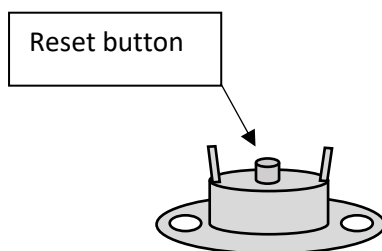

TO RESET THE ABOVE MESSAGES, FOLLOW THIS PROCEDURE:

- Press the manual drain button (4) on the unit.
- Press the down arrow button (3) for at least 5 seconds.

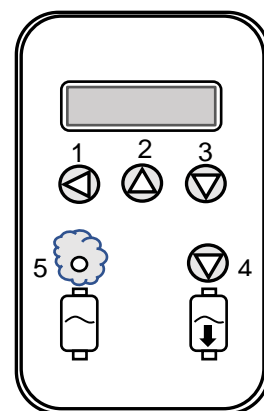

6. MAINTENANCE

6.1 STAINLESS STEEL TANK

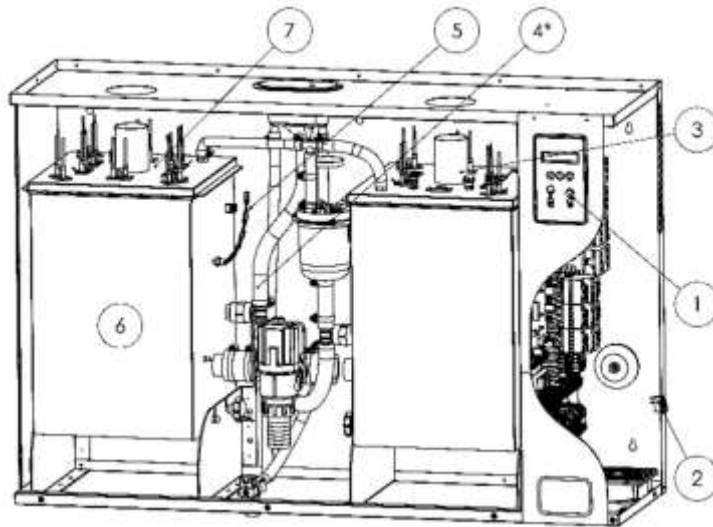

Fig. 6-1. Humidifier / stainless steel tank

- Drain the water by pressing the drain button (1). Wait for «DO MAINTENANCE » display.
- Cut the power supply to the power circuits (in the general electrical cabinet) and control circuits located on the side of the unit (2).
- Remove the door and unscrew the clamp (3). Completely disconnect the steam hose and remove it from the unit.
- Untighten clamp (s) and disconnect the water hose from the filling cup (4).
- Disconnect the pressure level hose and uncap the water level tank.
- Unscrew the union junction to disconnect the drain hose.
- Swing the tank down to intermediate position.
- Unlock the 4 locks of the tank.
- Lift the tank lid (7), mind the positioning marks and lay it upside down on the top of the humidifier.
- Release the tank holding steel cord and swing down the tank (5): the limescale deposit falls into a basin or our flexible bag (optional).
- Swing the tank (6) back to its intermediate position.
- Take off the collecting container and swing back the tank in intermediate position. Fasten the tank holding steel chain.
- Grease the tank gasket with silicon grease.
- Put back the tank lid onto the tank body taking care to align the positioning mark. Pay particular attention that no power wires be jammed between the tank and the bottom and gathered them in the insert bundle clip
- Wipe the high-water level floats or electrodes and put the water level detector back. Do not forget to reconnect the pressure level hose. Swing the tank up.
- Reassemble the drain valve in its original position and retighten the collar clamps.
- Tighten up the black knob, reconnect the drain and steam hoses and hang back the doors.

Take care: the tank gasket should be changed whenever the tank is maintained. Retighten all clamps.

Do not scratch harshly, hit or use corrosive liquids on the heating elements.

Very important:

- Do not use solvents to clean the water level detector. If you need to intervene on the detector, do not use special glues but only Teflon.

ELECTROVAP® RTH-HC

➤ **Check that the “T” and the anti-clogging system** of the tank have not been pulled down with the limescale deposit. Otherwise, pick it up from the collecting bag and reinstall it

6.2 DRAIN VALVE

The drain valve must be cleaned each time the steam tank is serviced or changed.

- Once your tank has been removed from the humidifier, disconnect the power cables from the drain solenoid valve (point 3).
- Unscrew clamp (point 1).
- You can now remove the complete valve.
- Wash the filter.
- Check and clean, if necessary, the inside of the valve body by running water through the hole.

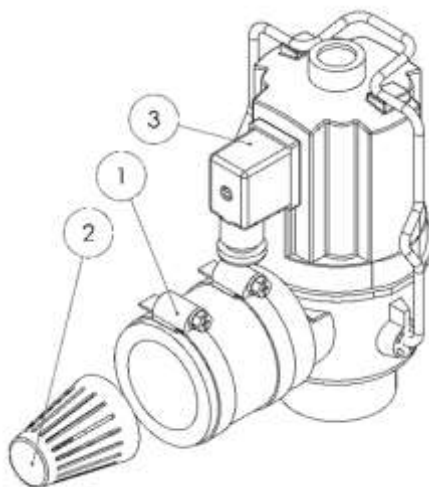

Fig. 6-2. Humidifier: drain valve

Reassemble the drain valve as before repositioning the tank, as follows:

1. install the cleaned cover.
2. tilt the tank backwards.
3. Install safety chain and cap nut.
4. Connect drain valve
5. Install the pipes and all hose clamps.

Make sure all hose clamps are tight when servicing the humidifier.

ELECTROVAP® RTH-HC

6.3 WATER INLET VALVE

The water inlet valve should be serviced after the first 50 hours of operation. Thereafter, at least twice a year.

- Switch off the device.
- Turn off the humidifier water supply and unscrew the water supply hose.
- Disconnect the power cables from your humidifier's water inlet valve (Item 1).
- Loosen clamp and remove water supply hose (Item 2).
- Unscrew the two valve fixing screws (Item 3).
- Take out your valve, remove the filter with pliers and remove the coil (Item 4) by levering with a screwdriver.
- Run water through the valve body and filter to remove any particles.

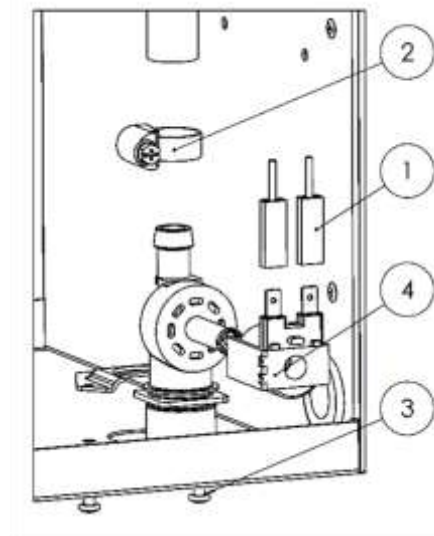

Once all these operations have been completed, reassemble the unit, taking care to check the condition of the water inlet hose clamp. You can now put your appliance back into service.

Every time you have your humidifier serviced, check that the clamps are in good condition and tight.

6.4 WATER LEVEL SENSOR

The level switch must be cleaned at each maintenance visit.

1. Disconnect cables from water level switch (1).
2. Unscrew the pressure-balancing tube clamp (2) and remove it from the cover.
3. To release the detector, unscrew the hose clamp (3) and disconnect the hose. **Caution: there may still be water inside the hose.**
4. Without unscrewing, clean the hose.
5. Unscrew the 3 screws (4) to clean the floats and level switch body.

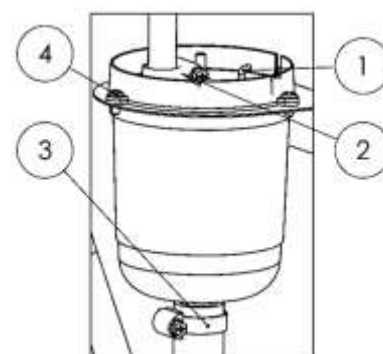

ELECTROVAP® RTH-HC

7. SPARE PARTS

7.1 STAINLESS STEEL CUVE

No	Code	Description
1	D111781-SP	Immersion heater nut M5
2	D110830-SP	Immersion heater support
3	D36282	Tank gasket
4	D110754-SP	High-temperature switch
5	D94057-SP	Probe lead-through
6	D94058-SP	Temperature sensor
7	D110765-230-SP	Immersion heater 230V 1900W
	D110765-277-SP	Immersion heater 277V 1900W
	D110765-346-SP	Immersion heater 346V 1900W
	D110765-398-SP	Immersion heater 398V 1900W
	D110761-230-SP	Immersion heater 230V 4300W
	D110761-277-SP	Immersion heater 277V 4300W
	D110761-346-SP	Immersion heater 346V 4300W
	D110761-398-SP	Immersion heater 398V 4300W
8	D110747-SP	"T" water supply
9	D94061-SP	Anti-clogging system
10	D110750-SP	Stainless steel bowl

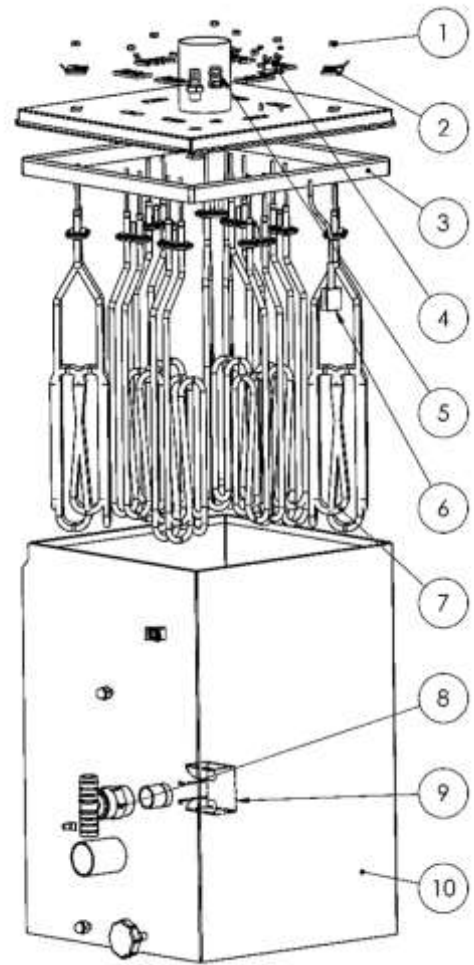

Fig. 7-1. Tank

If the tank is completely changed, use the reference below:

Complete tank Voltage RTH-HC model

↓ ↓ ↓

D110769-3x400-40

ELECTROVAP® RTH-HC

7.2 WATER INLET SOLENOID VALVE

N°	Code	Description
1-2	D110771-SP	Water inlet valve
2	D116645-24	24V coil
	D116645-24-UL	UL 24V coil
3	D111775-SP	Valve support

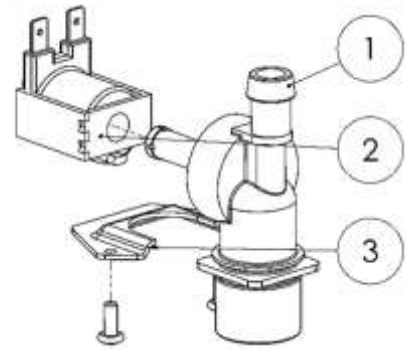

Fig. 7-2. Water inlet valve

7.3 WATER LEVEL SENSOR

N°	Code	Description
1 - 4 & 6	D110232-DI-SP	Level switch with float - complete
1	D108231-SP	Upper part Polypropylene
2	D108237-SP	Flat gasket for float (set of 3)
3	D80985-SP	Level sensor (set of 3)
4	D110734-SP	O-ring seal
5	D108230-SP	Stainless steel detector holder
6	D110735-SP	Bottom section Polypropylene

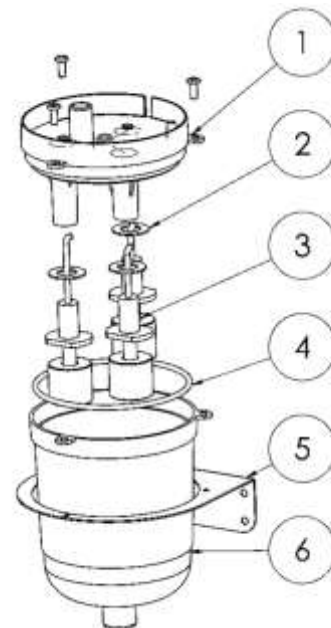

Fig. 7-3. Water level sensor

7.4 DRAIN SOLENOID VALVE

N°	Code	Description
1 - 3	D127990-SP	Complete Drain solenoid valve.
1	D108256-SP	Hose clamp
2	D110205-HC-SP	Filter
3	D128002-SP	Connector

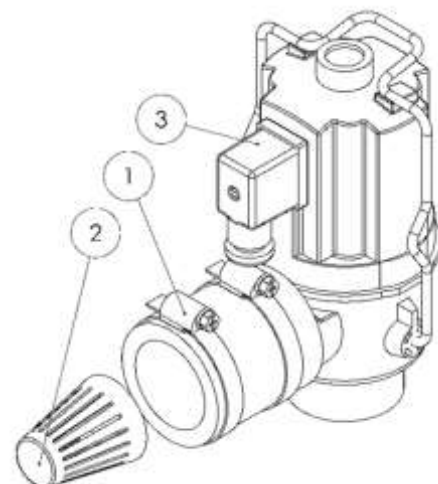

Fig. 7-4. Drain solenoid valve

ELECTROVAP® RTH-HC

7.5 ELECTRICAL PART

N°	Code	Description
1	D110124-SP	Display board
2	D121388-5-SP	RTH-HC main board (OTI)
3	D50931-SP	Information return board
4	D109737-SP	35mm ² power terminal (L1, L2, L3)
5	D110168-SP	Control terminal 16mm ² (L, N)
6	D107491-SP	2.5mm ² terminal (1, 2, 3, 4)
7	D110163-SP	35mm ² earth terminal.
8	D110806-600-60-SP	Solid-state relay RTH-HC 5 - 15 if Up[v] = 230-600V
	D110806-600-90-SP	Solid-state relay RTH-HC 20 - 100 if Up[v] = 230-600V
	D110806-690-75-SP	Solid-state relay RTH-HC if Up[v] = 690V
9	D50932-SP	24V contactor
10	D110173-SP	Double terminal 115/230V
11	D110768-SP	6mm ² fuse holder
12	D110166-SP	Stop
13	D110128-50-SP	Transformer Prim :2x115V Dry :2x12V
14	D92393-SP	On/off switch
	D116631-SP	Fast fuse 2A - 5 x 20 mm (Pack of 10)
	D116718-SP	Fast fuse 5A - 5 x 20 mm (Pack of 10)

Position	Amp.	Fuse protection
F1	2AT	Power contactor coil
F2	2AT	Inlet valve coil
F3	2AT	Drain valve coil
F4	2AT	Electronic boards
Din 5 & 6 rail	2AT	Transformer
Din 7 & 8 rail	5AT	Transformer

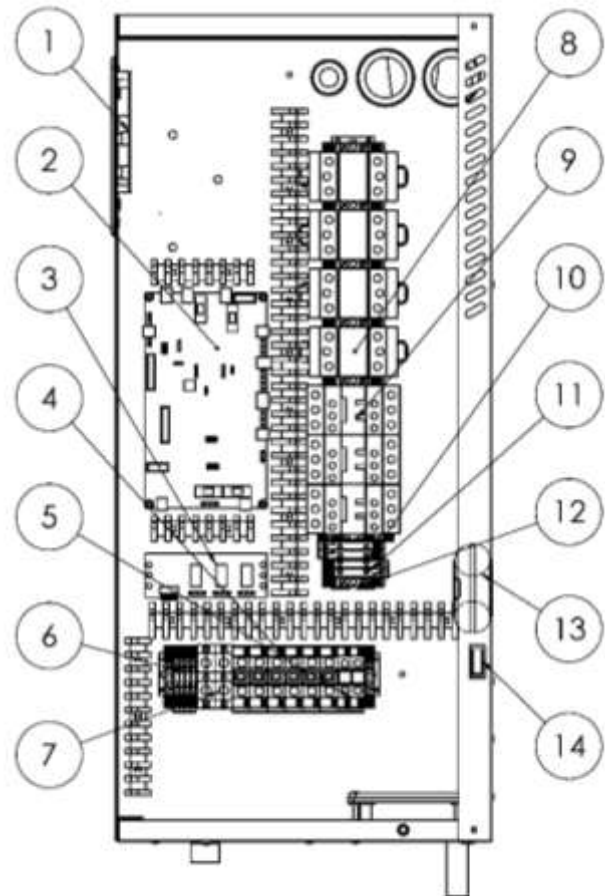

Fig. 7-5. Electrical compartment



185, Boulevard des Frères Rousseau

76550 Offranville - France

www.devatec.com

Export → Tel. +33 (0)2 35 83 06 44

Email : export@devatec.com