



## Instruction & Operation Manual



**STEAM GENERATOR FOR STEAM ROOM**  
**ElectroVap® STEAM BATH**



## Contents

<b>1 SAFETY INSTRUCTIONS</b>	<b>3</b>
1.1 INTRODUCTION	3
1.2 IMPORTANT REMARKS	4
1.3 DECLARATION OF CONFORMITY	5
1.4 RoHs DECLARATION	5
<b>2 PRODUCT RESENTATION</b>	<b>6</b>
2.1 CHARACTERISTICS	6
2.2 SIZE	7
2.3 STEAM GENERATOR COMPONENT PARTS	8
2.4 IMPORTANT INSTRUCTIONS	9
<b>3 INSTALLATION</b>	<b>10</b>
3.1 PROCEDURE	10
3.2 WATER SUPPLY	11
3.3 STEAM OUTLET	12
3.4 DRAIN HOSE CONNECTION	13
3.5 TEMPERATURE SENSOR POSITIONING	14
3.6 ELECTRICAL CONNECTIONS	15
<b>4 COMMISSIONING</b>	<b>33</b>
<b>5 SYSTEM MANAGEMENT</b>	<b>34</b>
5.1 USER INFORMATION (READ ONLY)	34
5.2 STEAM GENERATOR STATUS MENU	35
5.3 CHANGE SETTINGS MENU	36
5.4 MAINTENANCE ALERTS	39
5.5 DEFAULT MESSAGE	40
<b>6. MAINTENANCE</b>	<b>43</b>
6.1 GENERAL INFORMATION	43
6.2 STEAM CYLINDRE CLEANING	44
6.3 CYLINDER CLEANING METHOD	45
6.4 CYLINDER CLEANING METHOD	45
6.5 DRAIN VALVE	46
6.6 WATER INLET VALVE	47
<b>7. SPARE PARTS</b>	<b>48</b>
7.1 HYDRAULIC PART	48
7.2 WATER INLET VALVE	50
7.3 DRAINING CIRCUIT	50
7.4 ELECTRICAL PART	51
7.5 TEMPERATURE SENSOR	52
7.6 FUSES	52

# ElectroVap® STEAM BATH





## 1 SAFETY INSTRUCTIONS

### 1.1 INTRODUCTION

You recently purchased the steam generator ElectroVap® STEAM BATH, and we hope you enjoy this product. Thank you for the trust you place in us. The safety instructions contained in this manual are intended for specialized, qualified, and authorized personnel.

**To get the best results from the steam generator, we recommend to:**

- Read carefully the assembly and installation instructions in this manual.
- Keep this manual in a safe place for future reference.
- Transmit this manual in case of sale or transfer of the device, in order to guarantee the transmission of information about it.

AVERTISSEMENTS DE SÉCURITÉ ET SYMBOLES UTILISÉS DANS LE MANUEL	
	<b>Danger! Caution.</b> General safety instruction, whose violation could lead to malfunctions and / or bodily harm to person and / or property damage.
	<b>Danger! High voltage.</b> There are high voltages inside the device or one of its components, the negligence of this warning can lead to serious bodily injury or death to people and / or significant material malfunctions.
	<b>Danger! High temperature.</b> The ElectroVap® ELMC uses steam during the operation and therefore surfaces and pipe-work become very hot. Ensure that equipment not sustaining high temperatures is kept away. It is recommended to keep the temperature of the steam bath between 40°C and 50°C maximum. Above this temperature, there may be health risks.
	<b>Electrostatic hazard.</b> The components of the device may be subject to deterioration as they are very sensitive to electrostatic discharge.
	<b>Möbius strip.</b> Some components of the device are recyclable, the user is responsible for the removal of these. Follow the recycling recommendations adapted to the materials according to the geographical area.

- If your package is damaged or missing, please make a complaint to your carrier with a receipt acknowledgment letter within 24 hours and make a declaration to your Devatec agent.
- Pictures, graphics, and values may be subject to technical changes without notice.
- Keep this instruction manual carefully, and if you have any questions that are not answered in this manual, do not hesitate to contact us, or consult your Devatec agent.

**Our team will be pleased to be of assistance!**

# ElectroVap® STEAM BATH

## 1.2 IMPORTANT REMARKS

<b>GENERAL</b>	<p>This manual is a translation of the original French version. This manual contains all the details concerning the commissioning, operation, and maintenance of the ElectroVap® Steam Bath generator.</p> <p><b>Maintenance, service, repairs, as well as the study of the risks and dangers associated with these operations must be carried out by qualified, competent, and authorized personnel.</b></p> <ul style="list-style-type: none"><li>- Make sure that all risks or dangers are defined beforehand by an authorized person, especially for works-at-height.</li><li>- We also recommend installing a security perimeter.</li><li>- Make sure that the power supply is switched off before performing maintenance.</li><li>- Please screw periodically all the connection terminals of the power cable.</li></ul>
<b>INTENDED USE</b>	<p>This ElectroVap® STEAM BATH generator manufactured by Devatec is intended solely for the production of temperature-controlled steam for steam rooms within the specified operating conditions. The user undertakes to use it according to the safety instructions given in this manual.</p> <p>Improper use could result in serious hazards and damages to the user, third parties and materials.</p>
<b>STORAGE &amp; MAINTENANCE</b>	<p>The device must be stored in a dry, frost-free place, protected from shocks and vibrations. Maintenance must be carried out by at least two people or suitable lifting equipment.</p>
<b>WATER</b>	<p>The steam generators can be used with potable, demineralized, or softened water. It is absolutely forbidden to inject a chemical into the hydraulic system. Make sure that the water supply pressure does not exceed 8 bar. Always be careful that the installation meets local standards.</p>
<b>ELECTRICITY</b>	<p>The user ensures that electrical installation will be carried out by an authorized technician in this field. It is the installer's responsibility to provide the correct cable cross-section and protection by thermal-magnetic circuit breaker in accordance with the regulations in force in the country of installation. Ensure that the generator is earthed using a dedicated conductor.</p>
<b>WARRANTY</b>	<p>Devatec guarantees its equipment, excluding wearing parts, for 12 months after the date of installation or 15 months after the date of dispatch.</p> <p>Devatec's liability will be limited exclusively to Devatec's repair or replacement of the part or product, excluding labour, disassembly, or installation costs. Devatec may also decide to refund the purchase price of the product or part of it, at its discretion. The non-compliance of these above recommendations, additional mounting and / or transformation with components other than those provided with the device or any use other than what is explicitly stated, shall be considered as not in compliance with the prescriptions, and will invalidate the warranty.</p>
<b>LIABILITY</b>	<p>Devatec shall be not made liable for the consequences of incorrect installation, improper use of the devices and/or their components.</p> <p>We are committed to provide you the most complete manual, although, in the air treatment field, variations are so common that the information found in this document may be subject to changes without notice.</p>

# ElectroVap® STEAM BATH

## 1.3 DECLARATION OF CONFORMITY

The devices identified by serial numbers between 500 001 and 599 999, meets the requirements of the following European Directives:

2014/30/UE

2014/35/UE

<b>DEVICE TYPE</b>	Steam generator
<b>MODEL NAME</b>	ElectroVap® STEAM BATH
<b>MANUFACTURER</b>	Devatec 185 Boulevard des Frères Rousseau 76550 Offranville - FRANCE

We the undersigned, hereby declare that the equipment specified above conforms to the above Directive(s) and Standard(s). Valid for units with serial number starting from n° 500 001

FRAMBOT Jean-François  
General Manager  
05/01/2021



## 1.4 RoHs DECLARATION

Devatec,

Confirms that the ElectroVap® STEAM BATH steam generator is manufactured in compliance with the following European regulations:

**2011/65/UE**

This guideline regulates, after July 1<sup>st</sup> 2006, the use of mercury, cadmium, lead (soldering processes), chrome VI as well as PBB and PBDE.

MINFRAY Jean-Marie  
R&D Engineer  
05/01/2021



# ElectroVap® STEAM BATH

## 2 PRODUCT RESENTATION

### 2.1 CHARACTERISTICS

The ElectroVap® STEAM BATH is an electric steam generator, designed to control the air temperature in a steam room or hammam.

Standard delivery includes:

1. Steam generator
2. Temperature sensor with 10 m. long connecting cable
3. Technical documentation
4. 3 hose clamps (2 for the steam hose and 1 for the drain hose)

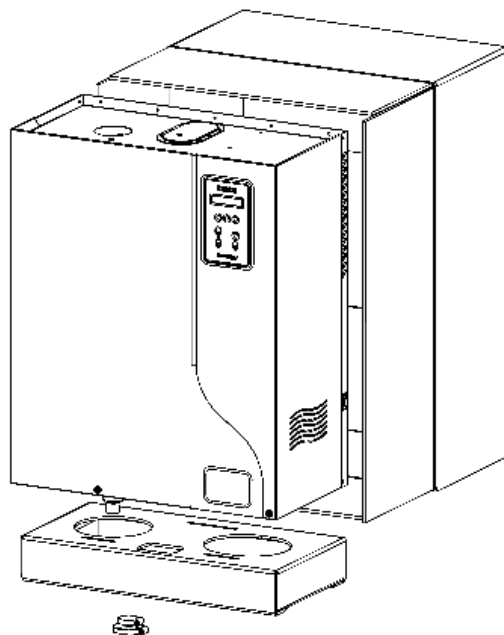

Fig. 2-1. Steam Generator ElectroVap®  
STEAM BATH

#### OPTIONS (Not supplied)

- Steam distribution nozzle
- Touch screen Steam Bath remote control with 3 or 8 dry contacts
- Bluetooth kit for mobile application
- Perfume dispenser
- Disinfecting system
- Emergency button
- Timer bath device
- Lights transformer
- LCD Display extension
- Steam and condensate hose
- Stainless steel braided hose in 3/4" FF (with gaskets) for connection to water network.
- Filling cup extension
- Additional cooling kit
- Mounting bracket
- Collecting water tank
- Steam pipe fittings (elbows, tees, bleed pots, etc.)

# ElectroVap® STEAM BATH

## 2.2 SIZE

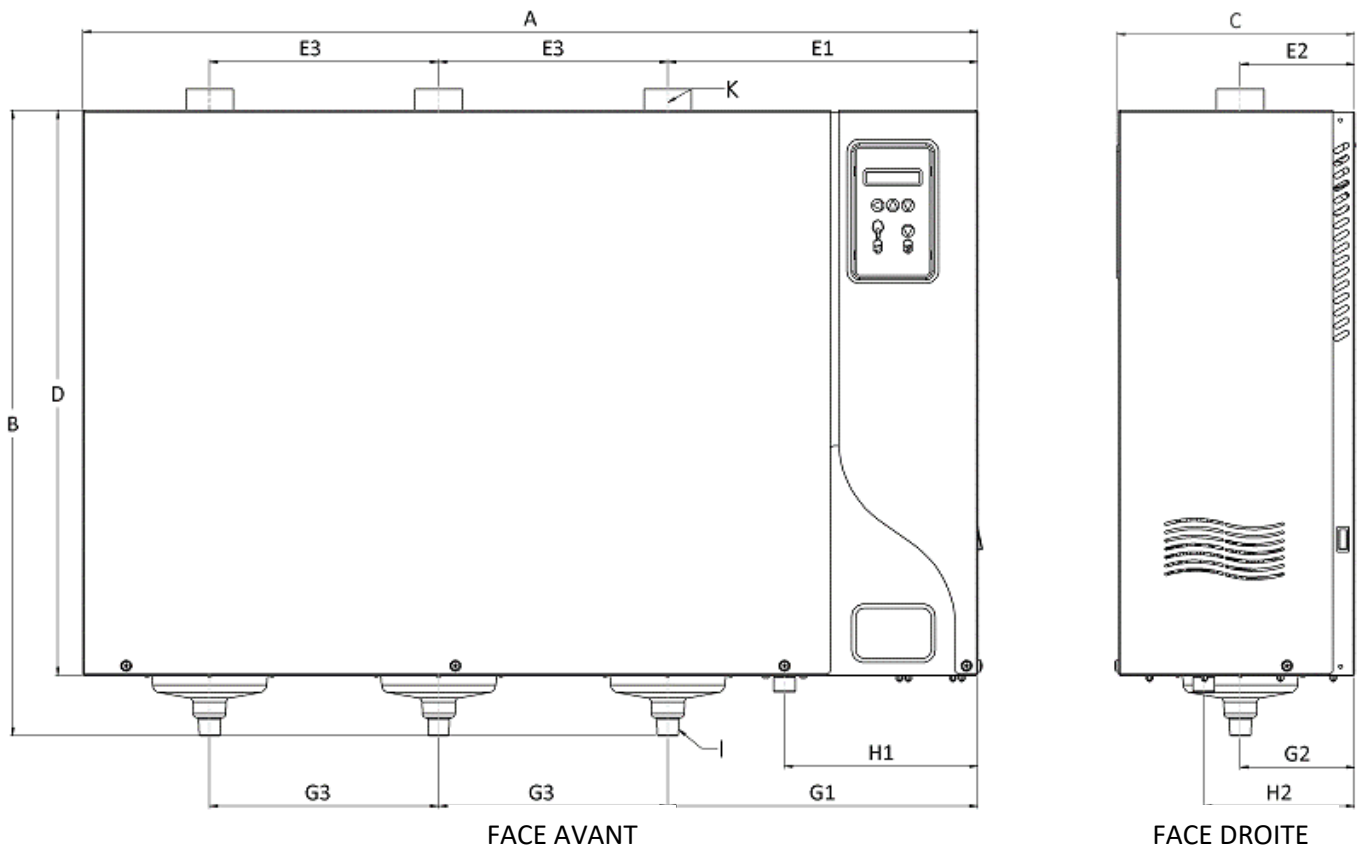

Fig. 2-2. Steam generator sizes

	ELMC 5-15 SB	ELMC 20-30 SB	ELMC 40-60 SB	ELMC 90 SB
Number of steam outputs	1	1	2	3
Dimensions [mm]				
A: Total width	469	554	794	1074
B: Total height	610	750	750	750
C: Depth	225	285	285	285
D: Height	538	678	678	678
E1: Steam outlet position	350	417	372	372
E2: Steam outlet position	111	137	137	137
E3: Distance between steam outputs			275	275
G1: Drain water position	350	417	372	372
G2: Drain water position	111	137	137	137
G3: Distance between draining water			275	275
H1: Water inlet position	222	222	222	222
H2: Water inlet position	141	181	181	181
I: Condensate outlet diameter	∅ 25	∅ 25	2 x ∅ 25	3 x ∅ 25
K: Steam output diameter	∅ 25 or 40	∅ 40 or 25	∅ 40 or 25	∅ 40 or 25
Mass [kg]				
Weight in operation	23	37	60	90
Gross weight (packed)	15	22	30	45



# ElectroVap® STEAM BATH

## 2.3 STEAM GENERATOR COMPONENT PARTS

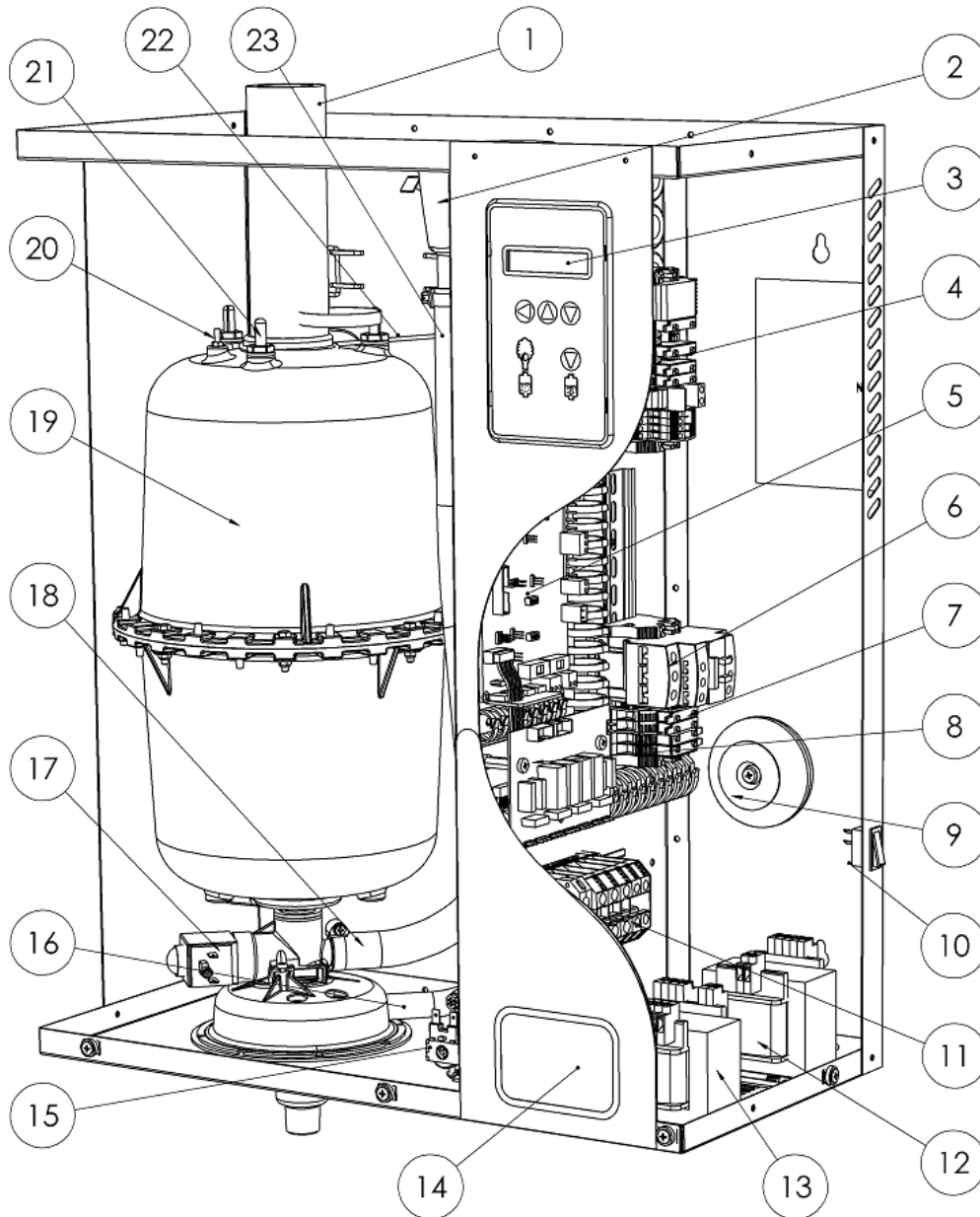

Fig. 2-3. Steam generator component parts

1	Steam hose	13	Command Transformer (option)
2	Filling cup	14	Identification label
3	LCD display board	15	Water inlet valve
4	DIN Rail (option)	16	Overflow hose
5	Main circuit board	17	Drain valve
6	Power contactor	18	Filling hose
7	Fuse holders	19	Steam Cylinder
8	3 or 8 relay board	20	High water level electrode
9	Transformer	21	Power electrode
10	ON/ OFF Switch	22	Cylinder retaining clip
11	Power rail	23	Filling hose
12	Light Transformer (option)		

# ElectroVap® STEAM BATH

## 2.4 IMPORTANT INSTRUCTIONS

- Ambient temperature: between 5 and 40°C
- Ambient humidity: < 80% Relative humidity
- Back side: this component heats during operation (up to 60°C). Make sure that the support of the device is not made of a heat-sensitive material.
- Wall mounting: Please be careful that the support material receiving the device (pillar, wall, etc.) can support it.
- Fixation: use a fastening system adapted to the support material.
- Make sure that the mounting distances are met.

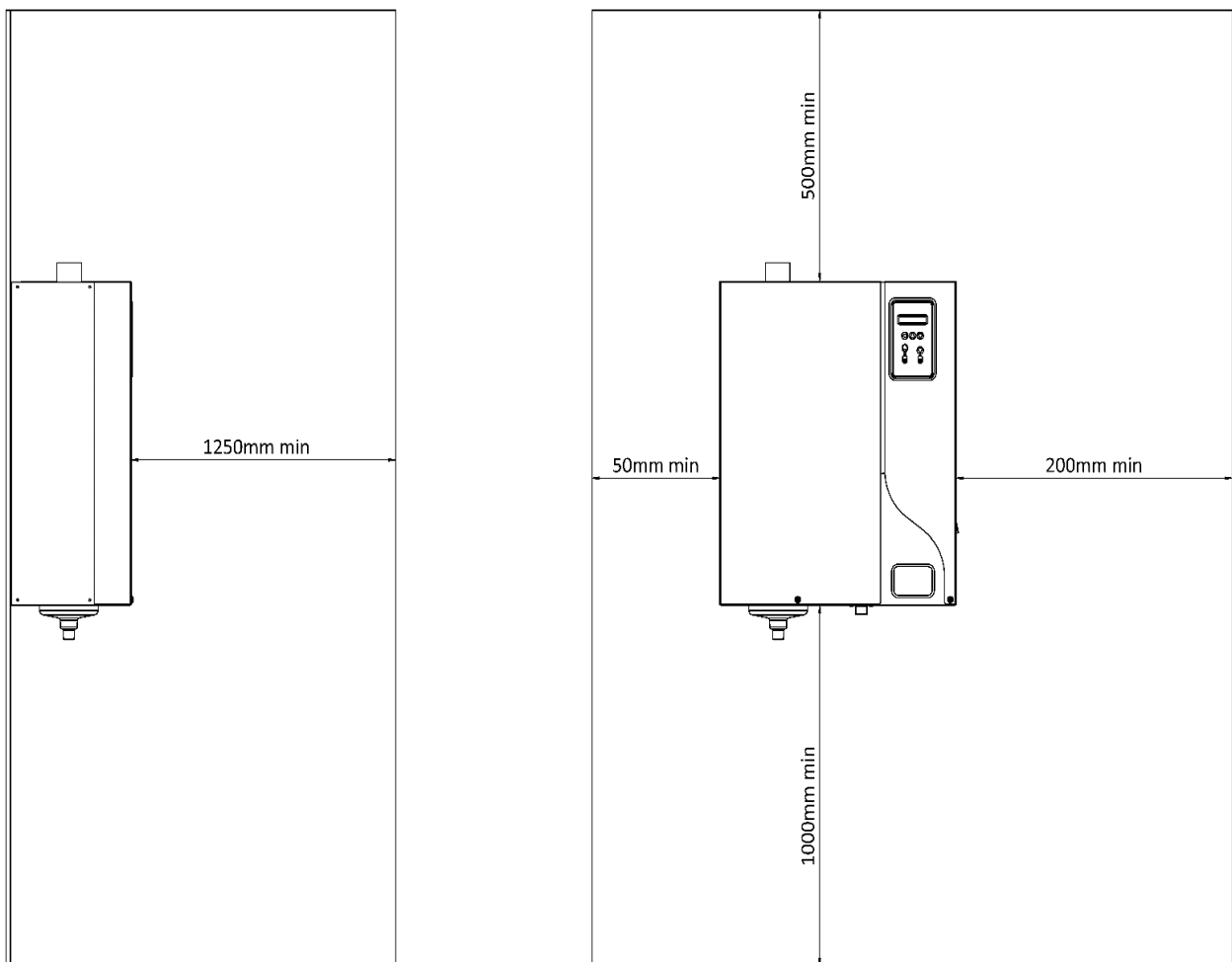

Fig.2-4. *Mounting distances*



Please read and follow the enclosed safety information and the warning labels inside the steam generator before installation or maintenance.

**Some steps can be dangerous.**

Visit our website or contact our operators for technical support.

# ElectroVap® STEAM BATH

## 3 INSTALLATION

### 3.1 PROCEDURE

- Mark and drill where indicated (holes size depends on the selected dowels and support materials).
- Put the dowels in the holes.
- Screw the top screws into the dowels (M6 recommended), let them protrude by about 10 mm/0.39in.
- Hang the device to the top screws and align it vertically and horizontally with a bubble level.
- Tighten up all 4 screws.

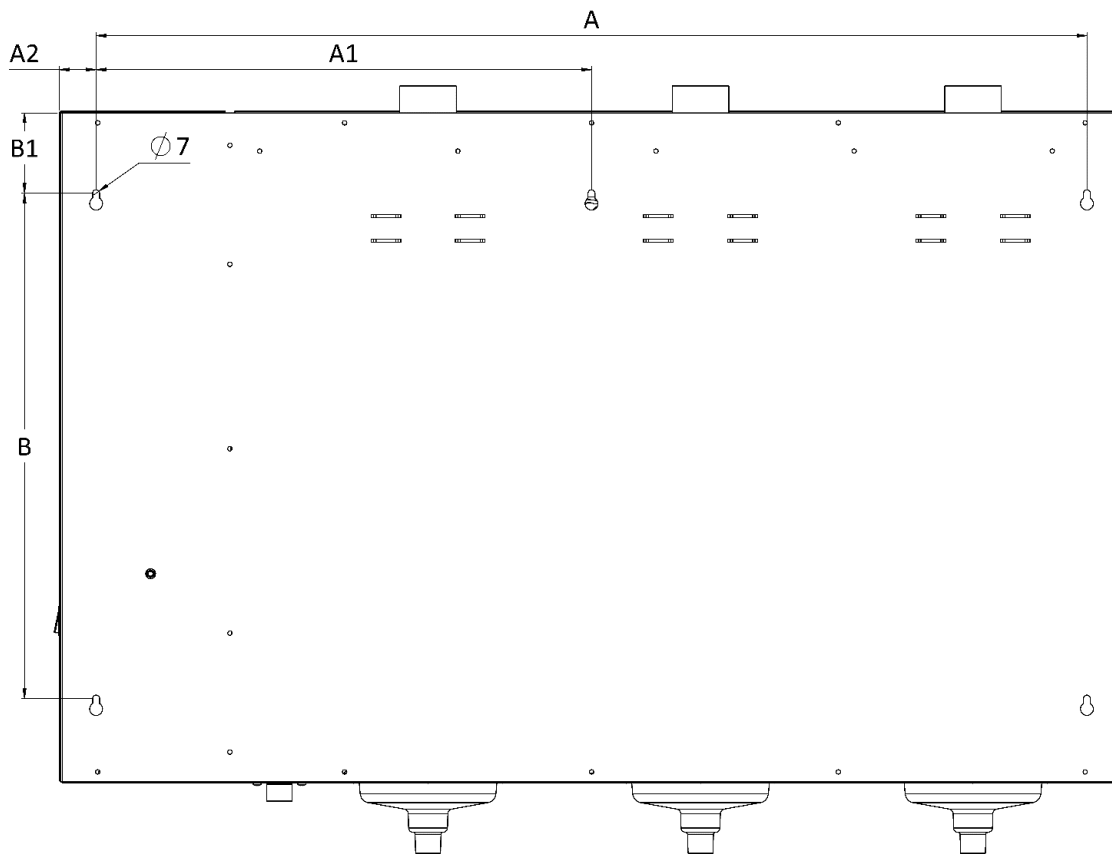

Fig. 3-1. Installation holes

	ELMC-SB 1 SC(*)	ELMC-SB 1 MC(*)	ELMC-SB 2 MC(*)	ELMC-SB 3 MC(*)
A:	400	450	750	1000
A1:				500
A2:	35	53	23	38
B:	400	510	510	510
B1:	81	81	81	81

(\*) SC = Small Cylinder - MC= Medium Cylinder

# ElectroVap® STEAM BATH

## 3.2 WATER SUPPLY

### 3.2.1 Recommendation

Our device is designed to be used with any following water type:

- ✓ Drinking water (according to Directive 98/83/EEC), TH (French grade) between 0°FH and 40°FH and conductivity between 250 µS/cm and 1000 µS/cm
- ✓ Softened water,
- ✓ Demineralized water, reverse osmosis water: use possible under conditions. Please contact our services

Fig. 3-2. Steam generator water supply

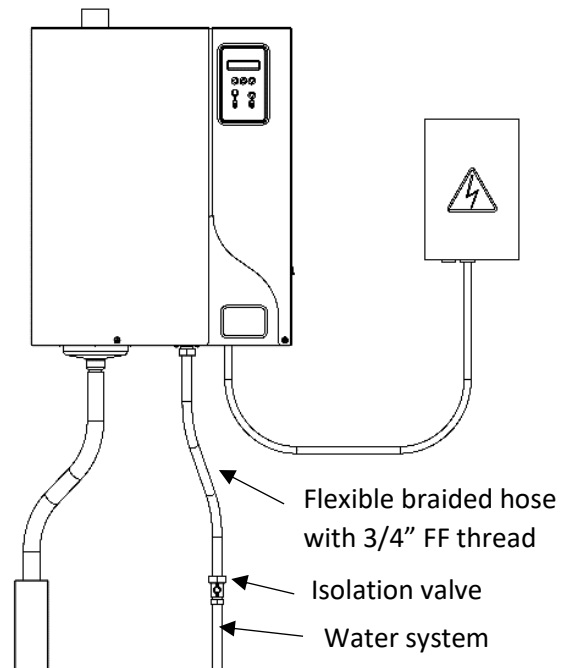

The demineralized water is corrosive; use appropriate piping material: stainless steel, PVC.

Softened water: Its use is not necessary, but possible. TH should be **between 0° fH and 2° fH**. Do not hesitate to contact our services for support.



An excess of sodium chloride may generate foam which disturbs the correct running of the steam generator.

**It is mandatory to use a duplex softener.**

### 3.2.2 Recommendation on connection

Network water pressure: The pressure must be steady and between 2 bar and 8 bar MAX. in case the water pressure exceeds 8 bar, a water regulator calve must be used.

Network water temperature: < 40 °C.

Please note that the water supply is connected at the lower part of the unit.

For easy maintenance, the water inlet valve is equipped with a filter strainer which should be checked periodically. It is essential to install an isolation valve near the steam generator to facilitate maintenance.



**OVERFLOW RISKS:** it is recommended to install a collecting water tank under the steam generators to prevent overflow. This is essential if the unit is installed in false ceilings or above important rooms. Make sure the container is connected to the wastewater system.

# ElectroVap® STEAM BATH

## 3.3 STEAM OUTLET

1. Preferably use a flexible steam hose that can withstand a temperature of 100°C.

Note: When new hoses are installed, a burnt plastic odour may occur when the steam generator is first turned on. This smell is normal and will decrease in time.

2. Selection of the steam hose:

Model	ELMC-SB 5 to 15	ELMC-SB 20 to 30	ELMC-SB 40 to 60	ELMC-SB 90
Quantity of steam outlets	1	1	2	3
Steam outlet diameter [mm]	Ø 40-25	Ø 40-25	Ø 40-25	Ø 40-25

3. For the installation of the steam hose, according to your environment, please respect the recommendations below and use the appropriate tangential clamps.

- Flexible steam hose max. length 3 m.
- Rigid stainless steel or copper tube with a slightly larger diameter, connected to earth. A flexible steam hose sleeve should be used to connect the generator to the rigid steam pipe. The length of the pipe should not exceed 6 m and it should be insulated.

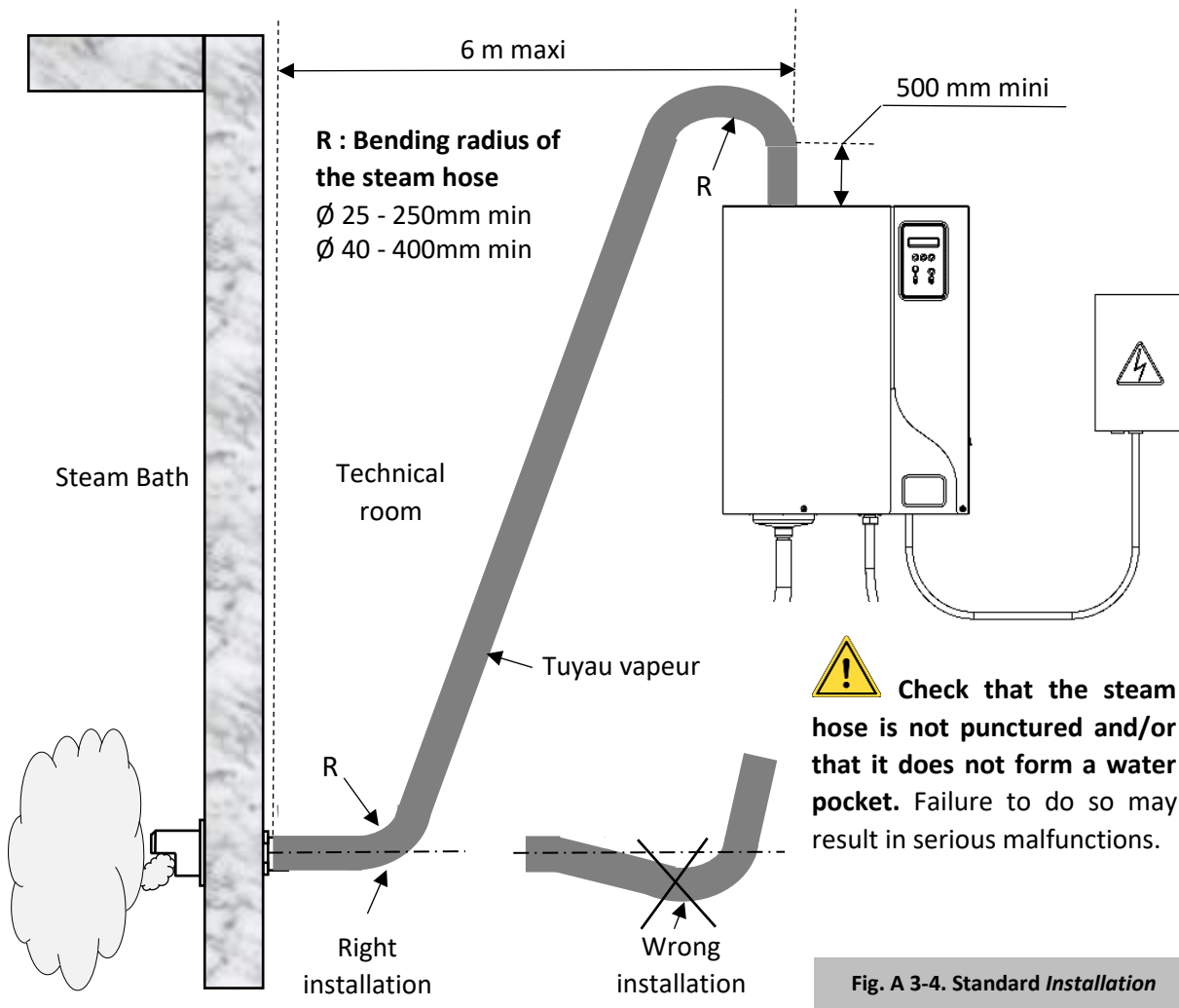

Fig. A 3-4. Standard Installation

# ElectroVap® STEAM BATH

## 3.4 DRAIN HOSE CONNECTION

The following drawing shows the connection of the drain hose that must be made.

Use a  $\varnothing$  25 mm rubber drain hose with the supplied hose clamp, heat resistant (up to 100°C). Connect the hose to the drain system. It is recommended to replace it regularly.

If you use a rigid pipe, it must be made of heat-resistant PVC (up to 100°C).

It is recommended that each generator has its own drain hose free of any obstacles.

We recommend the use of a collecting water tank (optional) with lid (see Fig.A 3-5) to collect limescale and cool the water before draining it through the pipes.



Keep a minimum pitch ( $\alpha$ ) of 10° for both the draining hose of the generator and for general drain pipe (see picture).



The drain hose should extend approximately 8 cm (d) into the sump. (The hose must never be in contact with the waste water in the collecting water tank)

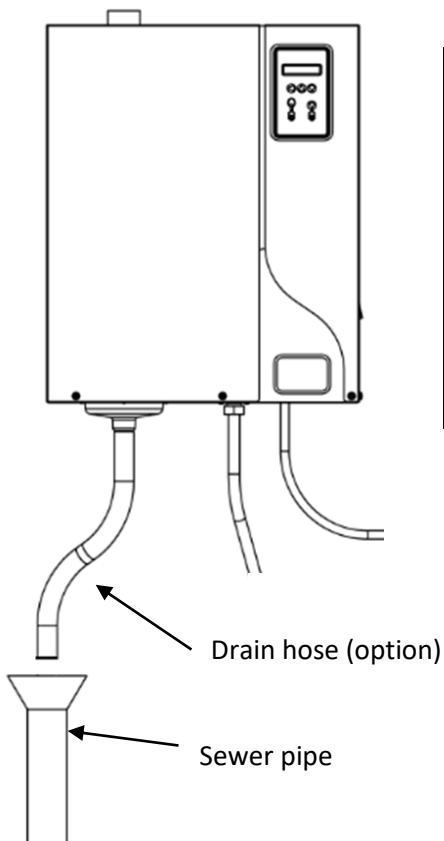

**Nota :** STEAM BATH are by design equipped with a condensate cooling system that guarantees the following cooling performance:

Unit	Max T°C during operation (*)	Max T°C for manual drain (*)	Max T°C max manual drain after 1h turned off (*)
ELMC-SB 1 SC/1MC	60°C	97°C	70°C
ELMC-SB 2 MC	60°C	97°C	70°C
ELMC-SB 3 MC	60°C	97°C	70°C

(\*) measured 1m after the unit draining

# ElectroVap® STEAM BATH

## 3.5 TEMPERATURE SENSOR POSITIONING

The temperature sensor monitors the temperature inside the steam room, and this information is then sent to the steam generator.

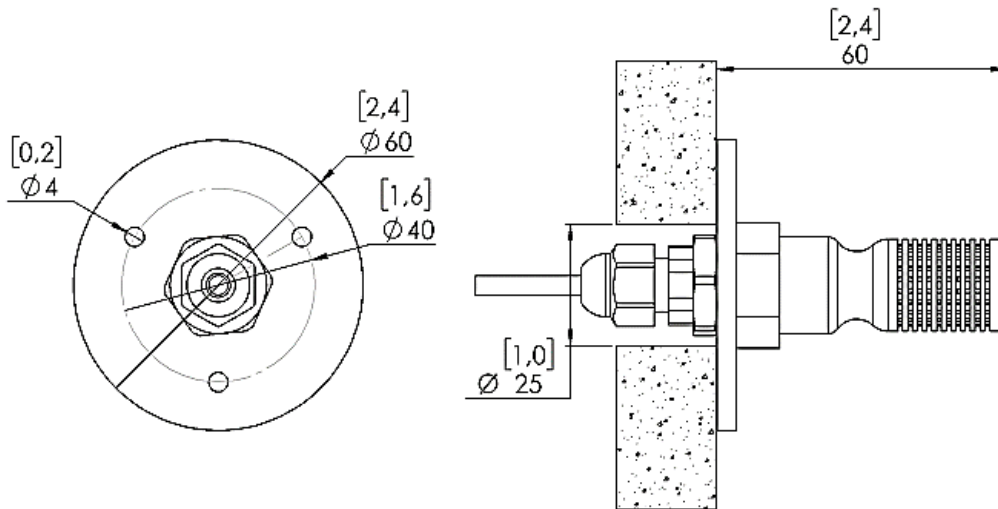

### Mounting

- Drill a hole of  $\varnothing 25$ mm in your wall
- Insert the cable in the hole and from the inside of the hammam.
- Mark and drill the 3 holes opposite, put in the dowels.
- Make a silicone seal between the  $\varnothing 60$ mm washer and the wall, then fix the temperature sensor with 3 screws.
- To avoid a possible steam leakage, you can fill the hole of the cable passage with silicone.

### Positioning

Recommended installation

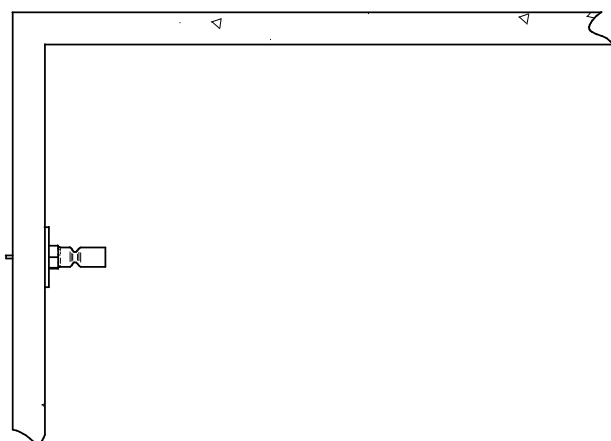

Exceptional installation

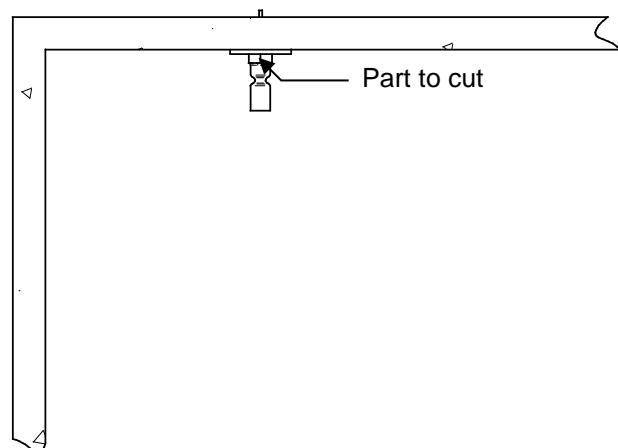

If you fix the temperature sensor to the ceiling of your steam room, it is possible to have a slight water retention at the end of the white strainer of the sensor. In this case we advise you to cut the end of the strainer.

# ElectroVap® STEAM BATH

## 3.6 ELECTRICAL CONNECTIONS

### 3.6.1 Technical data

Supply (V)	ELMC-SB	5	8	10	15	20	30	30HC	40	50	60	60HC	90	90HC
220V - 1 ph	I (A)	18,0		36,1										
	P (kW)	4,0		7,9										
	Prod. (kg/h)	5,0		10,0										
	Cylinder	1 x SC		1 x MC										
230V - 1 ph	I (A)	17,3		34,6										
	P (kW)	4,0		8,0										
	Prod. (kg/h)	5,0		10,0										
	Cylinder	1 x SC		1 x MC										
200V - 3ph	I (A)	11,5	18,4	22,9	34,4	45,8	69,7		91,6	114,6	137,3			
	P (kW)	4,0	6,4	8,0	12,0	15,9	24,2		31,9	39,9	47,8			
	Prod. (kg/h)	5,0	8,0	10,0	15,0	20,0	30,4		39,9	50,0	59,9			
	Cylinder	1 x MC	1 x MC	1 x SC	1 x MC	1 x MC	2 x MC		2 x MC	3 x MC	3 x MC			
208V - 3ph	I (A)	11,0	17,5	21,8	32,7	43,7	66,3		87,3	109,5	131,0			
	P (kW)	4,0	6,4	8,0	12,0	16,0	24,2		31,9	40,0	47,9			
	Prod. (kg/h)	5,0	8,0	10,0	15,0	20,0	30,3		40,0	50,1	60,0			
	Cylinder	1 x MC	1 x MC	1 x SC	1 x MC	1 x MC	2 x MC		2 x MC	3 x MC	3 x MC			
220V - 3ph	I (A)	10,6	16,7	20,8	30,8	41,6	69,7		84,4	104,5	126,6			
	P (kW)	4,0	6,4	8,0	11,8	15,9	26,7		32,3	40,0	48,5			
	Prod. (kg/h)	5,1	8,0	10,0	14,8	19,9	33,4		40,5	50,1	60,7			
	Cylinder	1 x MC	1 x MC	1 x SC	1 x MC	1 x MC	2 x MC		2 x MC	3 x MC	3 x MC			
230V - 3ph	I (A)	10,1	16,2	20,2	30,2	40,3	66,3		80,6	100,7	120,9			
	P (kW)	4,1	6,5	8,1	12,1	16,1	26,5		32,3	40,3	48,4			
	Prod. (kg/h)	5,1	8,1	10,1	15,1	20,2	33,2		40,4	50,5	60,6			
	Cylinder	1 x MC	1 x MC	1 x SC	1 x MC	1 x MC	2 x MC		2 x MC	3 x MC	3 x MC			
380V - 3ph	I (A)	6,3	9,6	12,0	18,0	24,0	36,1	38,2	48,1	60,4	72,6	76,4	110,8	114,6
	P (kW)	4,2	6,4	8,0	11,9	15,9	23,9	25,3	31,8	39,9	48,0	50,5	73,3	75,8
	Prod. (kg/h)	5,2	8,1	10,0	14,9	19,9	29,9	31,6	39,9	50,0	60,1	63,3	91,8	94,9
	Cylinder	1 x MC	1 x MC	1 x SC	1 x SC	1 x MC	1 x MC	1 x MC	2 x MC	2 x MC	2 x MC	2 x MC	3 x MC	3 x MC
400V - 3ph	I (A)	5,8	9,3	11,6	17,4	23,2	34,8	37,6	46,4	57,9	69,7	75,1	104,5	112,7
	P (kW)	4,0	6,5	8,1	12,1	16,2	24,2	26,1	32,3	40,3	48,5	52,3	72,7	78,4
	Prod. (kg/h)	5,1	8,1	10,1	15,2	20,2	30,4	32,8	40,5	50,4	60,7	65,5	91,1	98,3
	Cylinder	1 x MC	1 x MC	1 x SC	1 x SC	1 x MC	1 x MC	1 x MC	2 x MC	2 x MC	2 x MC	2 x MC	3 x MC	3 x MC
420V - 3ph	I (A)	5,6	9,0	11,2	16,8	22,4	33,6	36,3	44,7	56,2	67,1	72,6	100,7	108,9
	P (kW)	4,1	6,6	8,2	12,3	16,3	24,5	26,5	32,7	41,1	49,1	53,1	73,6	79,6
	Prod. (kg/h)	5,1	8,2	10,2	15,4	20,5	30,7	33,2	41,0	51,4	61,4	66,5	92,2	99,7
	Cylinder	1 x MC	1 x MC	1 x SC	1 x SC	1 x MC	1 x MC	1 x MC	2 x MC	2 x MC	2 x MC	2 x MC	3 x MC	3 x MC
440V - 3ph	I (A)	5,3	8,5	10,6	15,8	21,1	31,7	34,0	42,2	52,8	63,3	68,0	95,0	102,0
	P (kW)	4,0	6,5	8,1	12,1	16,2	24,2	26,0	32,3	40,4	48,5	52,0	72,7	78,1
	Prod. (kg/h)	5,1	8,1	10,1	15,2	20,2	30,4	33,6	40,5	50,6	60,7	65,2	91,1	97,8
	Cylinder	1 x MC	1 x MC	1 x SC	1 x SC	1 x MC	1 x MC	1 x MC	2 x MC	2 x MC	2 x MC	2 x MC	3 x MC	3 x MC
460V - 3ph	I (A)	5,1	8,0	10,1	15,1	20,2	30,4	32,7	40,3	50,7	60,8	65,4	91,2	98,2
	P (kW)	4,1	6,4	8,1	12,1	16,1	24,3	26,2	32,3	40,6	48,7	52,4	73,0	78,6
	Prod. (kg/h)	5,1	8,0	10,2	15,1	20,2	30,5	32,8	40,4	50,8	60,9	65,6	91,4	98,4
	Cylinder	1 x MC	1 x MC	1 x SC	1 x SC	1 x MC	1 x MC	1 x MC	2 x MC	2 x MC	2 x MC	2 x MC	3 x MC	3 x MC
480V - 3ph	I (A)	4,9	7,7	9,7	14,5	19,3	29,1	31,5	38,6	48,6	57,9	62,9	87,4	94,4
	P (kW)	4,1	6,5	8,1	12,1	16,1	24,3	26,3	32,3	40,6	48,3	52,5	73,0	78,8
	Prod. (kg/h)	5,1	8,1	10,2	15,1	20,2	30,5	32,9	40,4	50,8	60,5	65,8	91,4	98,7
	Cylinder	1 x MC	1 x MC	1 x SC	1 x SC	1 x MC	1 x MC	1 x MC	2 x MC	2 x MC	2 x MC	2 x MC	3 x MC	3 x MC
575V - 3ph	I (A)	4,0	6,5	8,0	12,1	16,2	24,3	26,4	32,3	40,2	48,6	52,8	72,9	79,2
	P (kW)	4,1	6,5	8,1	12,3	16,3	24,5	26,6	32,6	40,5	49,0	53,3	73,6	79,9
	Prod. (kg/h)	5,1	8,1	10,1	15,3	20,4	30,7	33,4	40,8	50,7	61,4	66,7	92,0	100,0
	Cylinder	1 x MC	1 x MC	1 x SC	1 x SC	1 x MC	1 x MC	1 x MC	2 x MC	2 x MC	2 x MC	2 x MC	3 x MC	3 x MC
600V - 3ph	I (A)	3,9	6,3	7,7	11,6	15,5	23,2	25,4	31,0	38,5	46,5	50,7	69,7	76,1
	P (kW)	4,1	6,5	8,1	12,1	16,2	24,3	26,5	32,4	40,2	48,5	52,9	72,8	79,4
	Prod. (kg/h)	5,1	8,1	10,1	15,2	20,3	30,4	33,1	40,6	50,2	60,7	66,2	91,1	99,4
	Cylinder	1 x MC	1 x MC	1 x SC	1 x SC	1 x MC	1 x MC	1 x MC	2 x MC	2 x MC	2 x MC	2 x MC	3 x MC	3 x MC
690V - 3ph	I (A)	3,4	5,4	6,8	10,1	13,4	20,3	22,2	26,8	33,9	40,6	44,4	60,9	66,6
	P (kW)	4,1	6,5	8,1	12,2	16,1	24,4	26,6	32,2	40,6	48,7	53,3	73,1	79,9
	Prod. (kg/h)	5,1	8,1	10,2	15,2	20,2	30,5	33,3	40,3	50,8	60,9	66,7	91,4	100,0
	Cylinder	1 x MC	1 x MC	1 x SC	1 x SC	1 x MC	1 x MC	1 x MC	2 x MC	2 x MC	2 x MC	2 x MC	3 x MC	3 x MC

SC = Small Cylinder - MC= Medium Cylinder



# ElectroVap® STEAM BATH

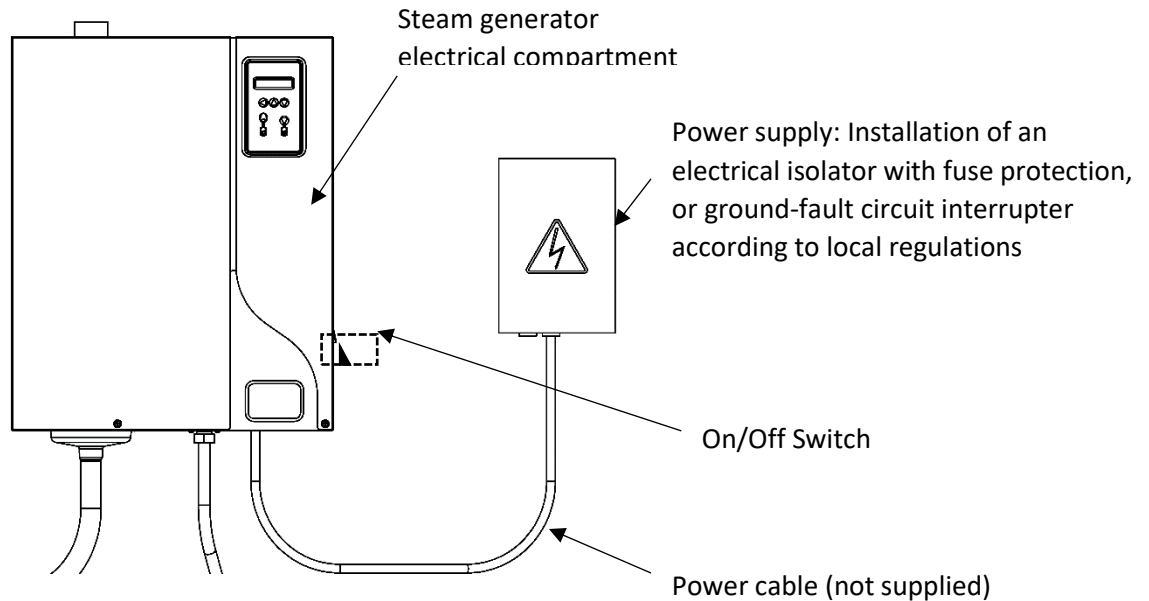

A 3-6. Connexions électriques



**All work on the electrical parts must be carried out by qualified and authorized personnel.**

In addition, before making any electrical connections, check that your installation has been determined from the values in the below table.

Respect local regulation concerning electrical connections.



Electronic components are sensitive to electrostatic charges. When working on these components, take appropriate measures to avoid electrostatic discharges.



All electrical wiring must enter the unit through a cable gland (not supplied).



Unit switch: when the unit is switched off, there is still high voltage inside the unit. **Electric shock may be fatal, electrical isolator must be switched off.**



Wiring terminals are : L1, L2, L3 (35mm<sup>2</sup>), and L, N (16mm<sup>2</sup>)  
Please adapt the copper wire dimension to the terminals

# ElectroVap® STEAM BATH

## 3.6.2 Electrical wiring

Up [V] = POWER VOLTAGE

Uc [V] = CONTROL VOLTAGE

Up(V) = 1x200 - 230Vac (50-60Hz)

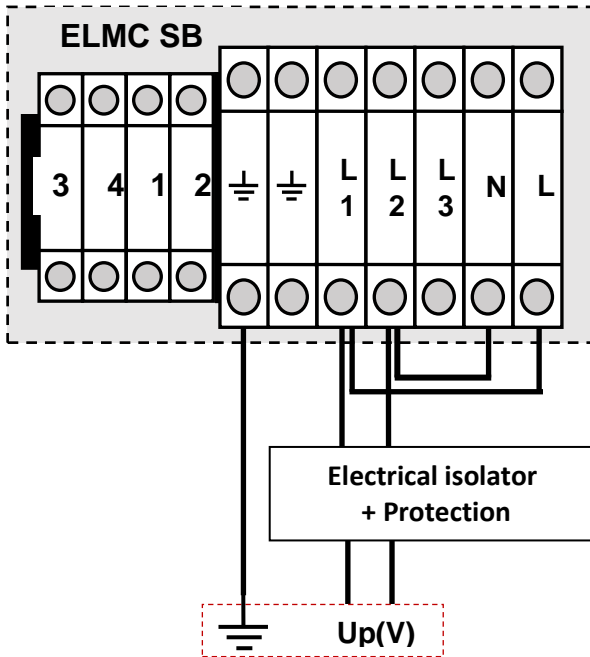

Up(V) = 3x200 - 230Vac (50-60Hz)

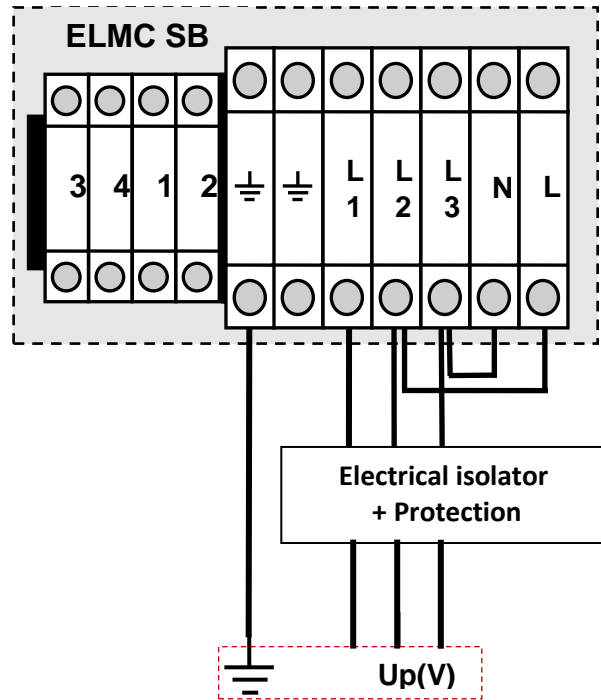

Up(V) = 3x380 - 420Vac (50-60Hz)  
with neutral

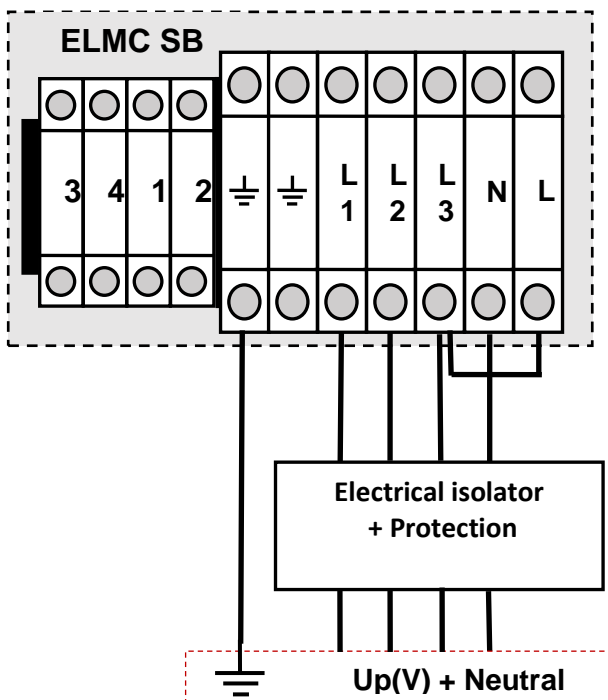

Up(V) = 3x380 - 690Vac (50-60Hz)  
Uc (V) = 1x200 - 230Vac (50-60Hz)

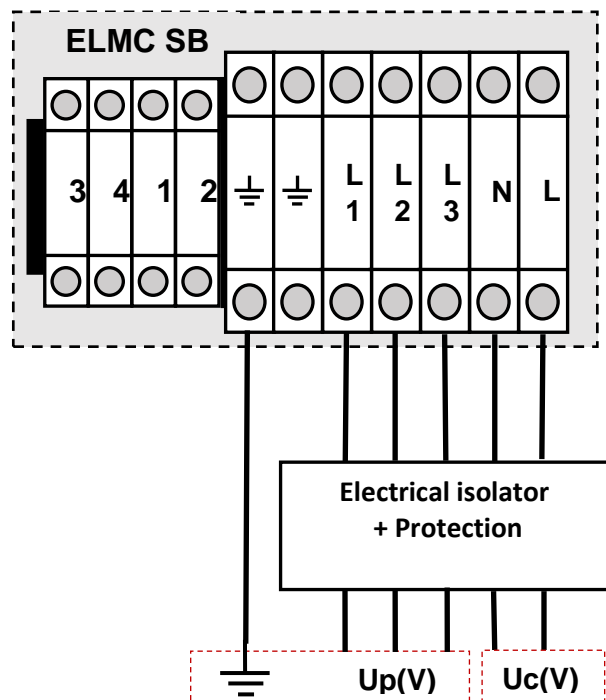

# ElectroVap® STEAM BATH

Up(V) = 3x380–690Vac (50-60Hz)

**MANDATORY OPTION** : Transformer : sec : 2x115V

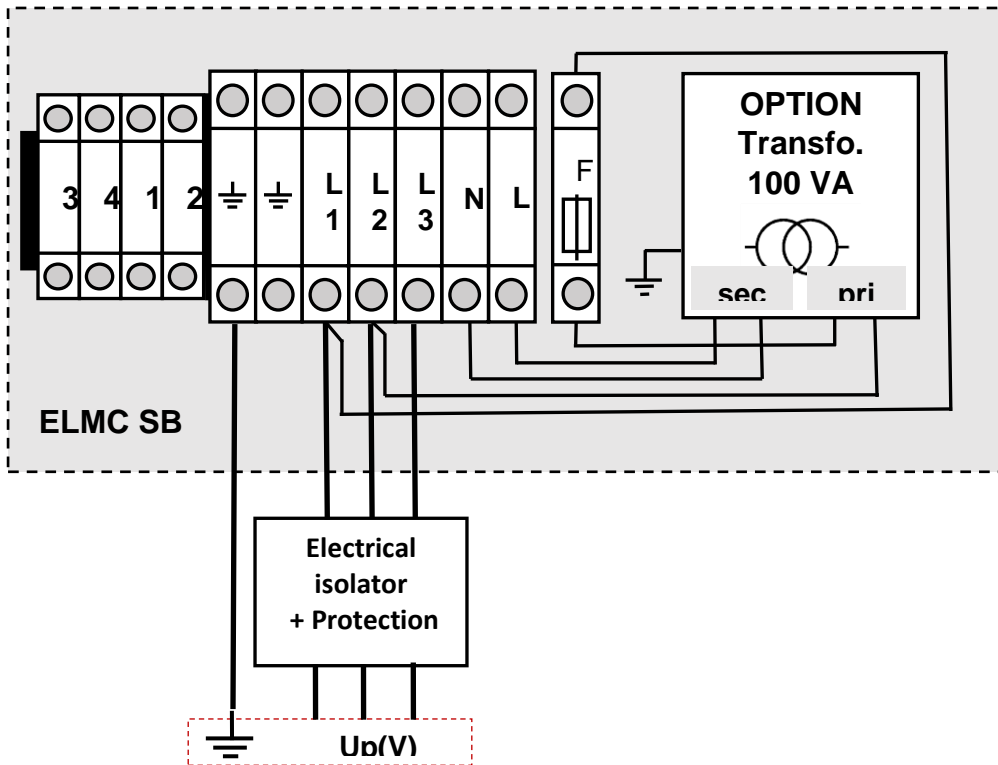

## 3.6.3 Options wiring

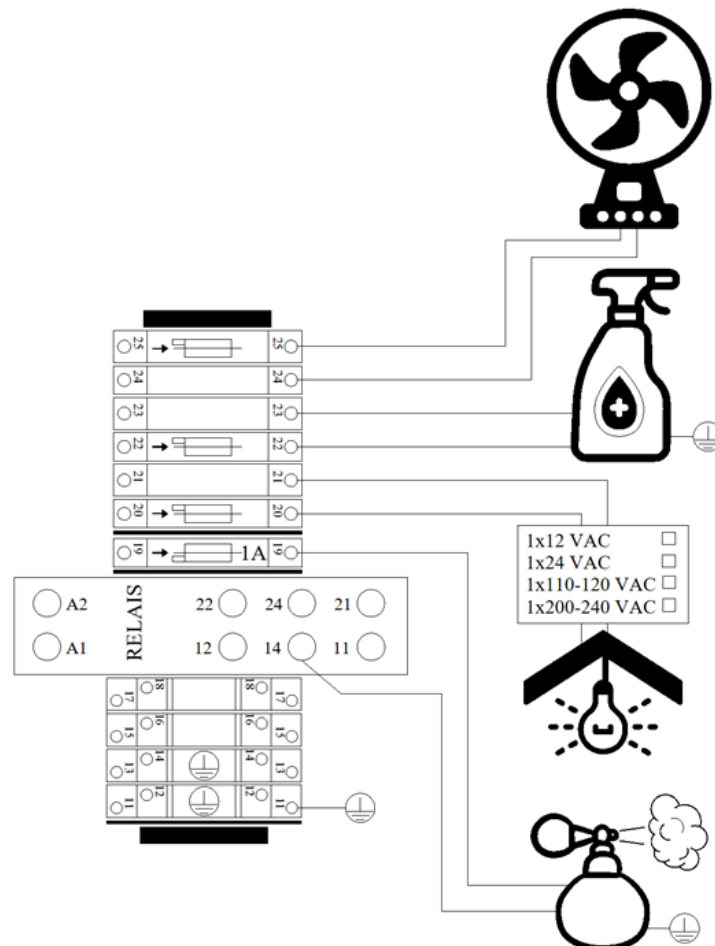

# ElectroVap® STEAM BATH

## With Touch Screen option

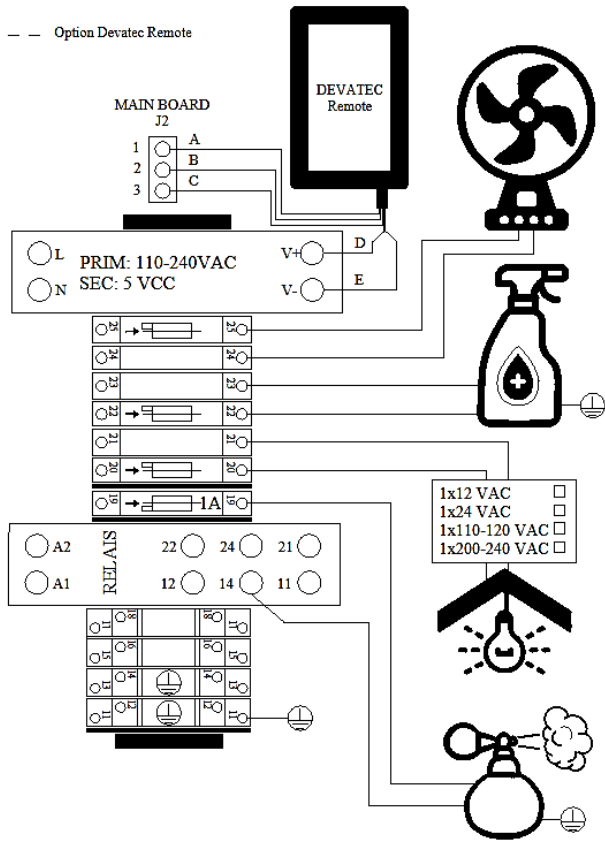

## With Gateway option

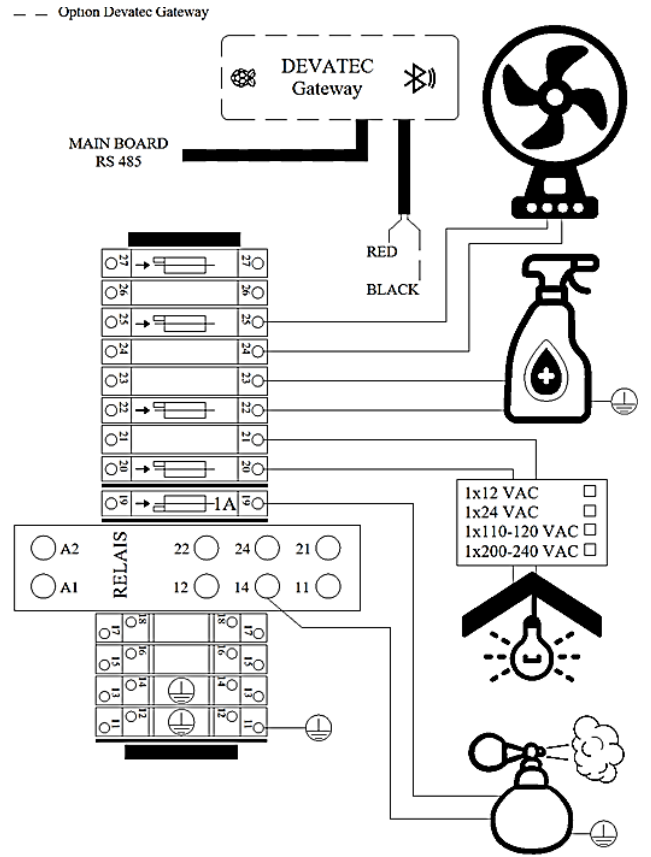

# ElectroVap® STEAM BATH

## 3.6.4 Raccordement sonde de température

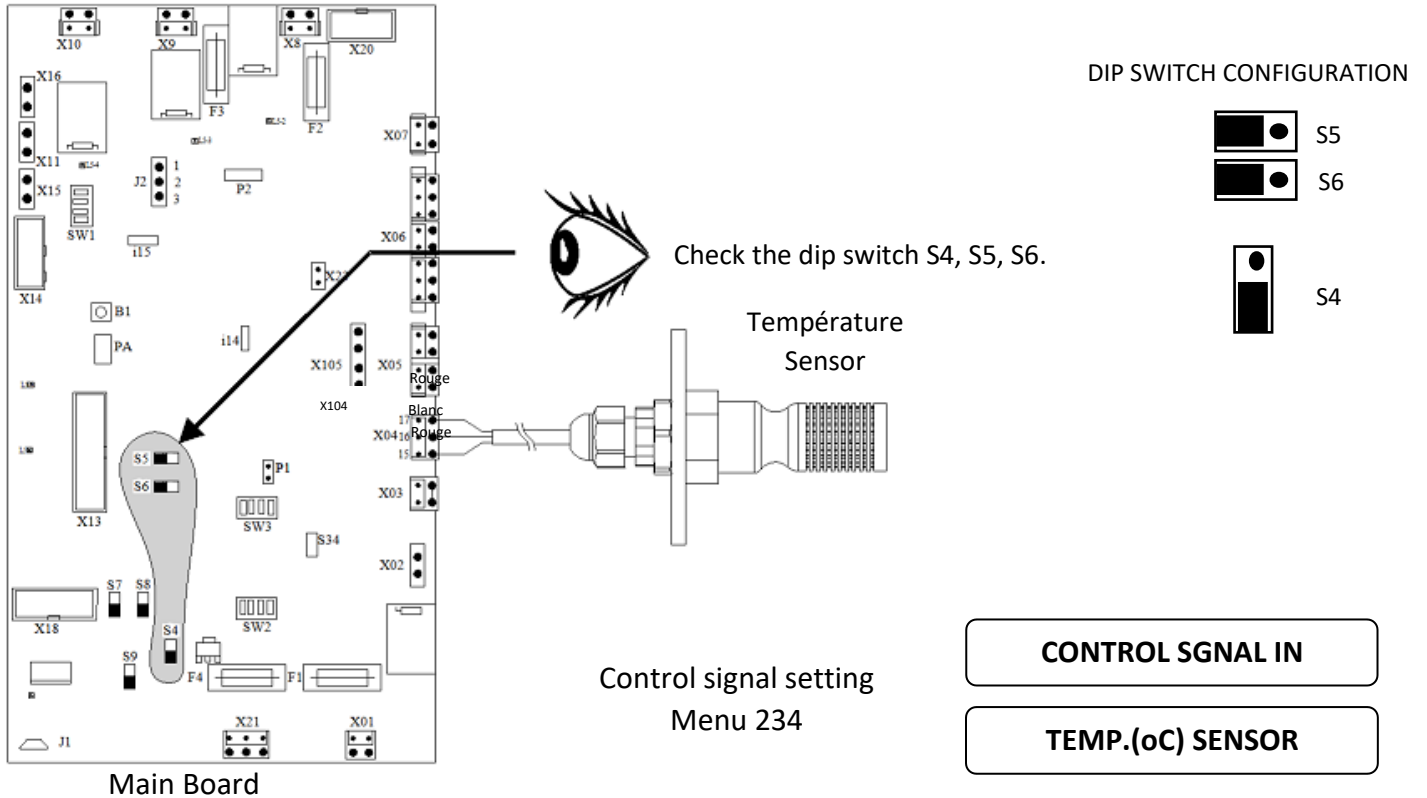

The contact between 1 & 2 on the DIN rail must be closed to authorize operation.  
If there is no safety contact, make a bridge.

## 3.6.5 On/Off Control and Safety Contacts

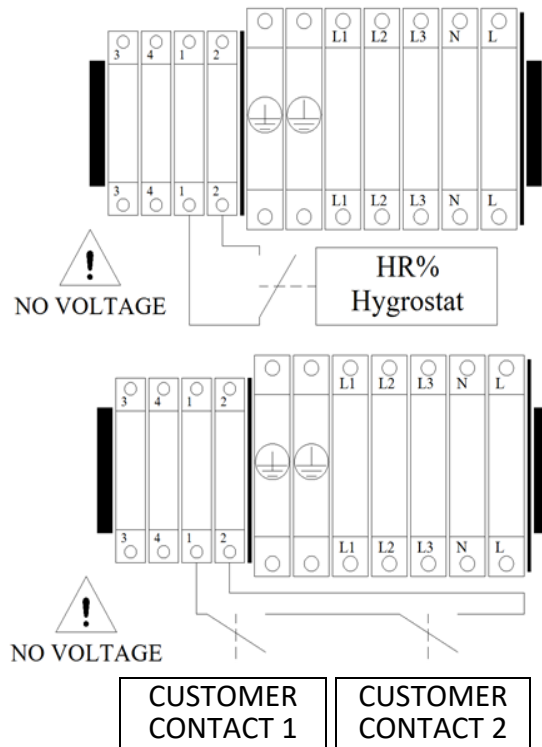

On/Off configuration:

Fit a thermostat to control operation.

**The contact between 1 & 2 must be closed to authorize operation.**

Configuration with safety contact(s):

Detector(s) to be connected in series to terminals 1 and 2.

Example: Door open detection thermostat.

# ElectroVap® STEAM BATH

## 3.6.6 8 dry contacts board (option)

### 3 dry contacts board (Standard)

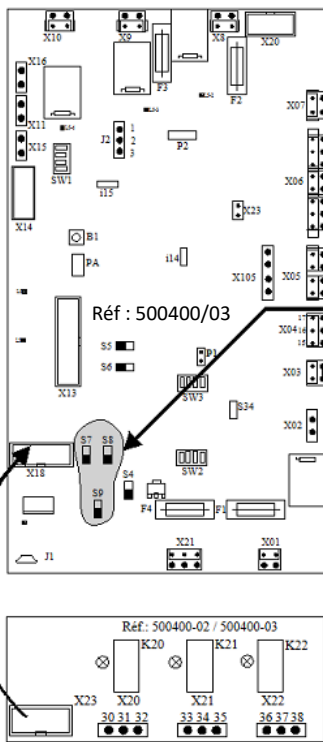

Check the jumper  
S7, S8, S9.

### 8 dry contacts board (Option)

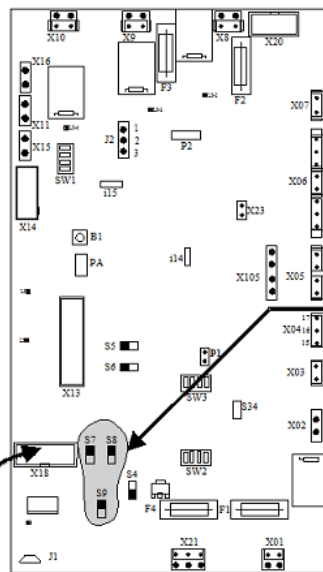

#### DIP SWITCH CONFIGURATION

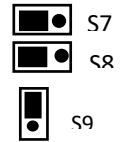

Check the jumper  
S7, S8, S9.

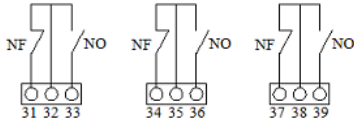
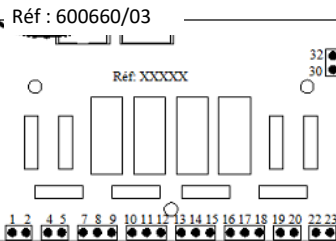

#### Control of various terminal blocks :

- 30-31-32 : Service Light (5A)
- 33-34-35 : Disinfectant (5A)
- 36-37-38 : Ventilation Control (5A)

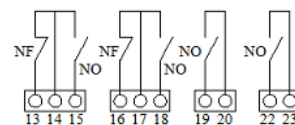
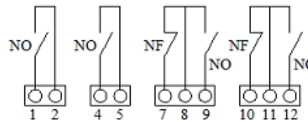

#### Control of various terminal blocks :

- 1-2 : Operating light(5A)
- 4-5 : Disinfectant (5A)
- 7-8-9 : Ventilation control (10A)
- 10-11-12 : Mood light (10A)
- 13-14-15 : Option 1 (10A)
- 16-17-18 : Option 2 (10A)
- 19-20 : Option 3 (5A)
- 22-23 : Option 4 (5A)

# ElectroVap® STEAM BATH

## 3.6.7 RS485 – BUS connection

RS485 connection must be plugged on the J2 connector:

- Terminal 1: Data -
- Terminal 2: Data +
- Terminal 3: GND

The SW1 switch is used to turn line resistance on or off. Depending on your needs, these resistances can be activated or deactivated (see diagram).

Fig. B 3-8.

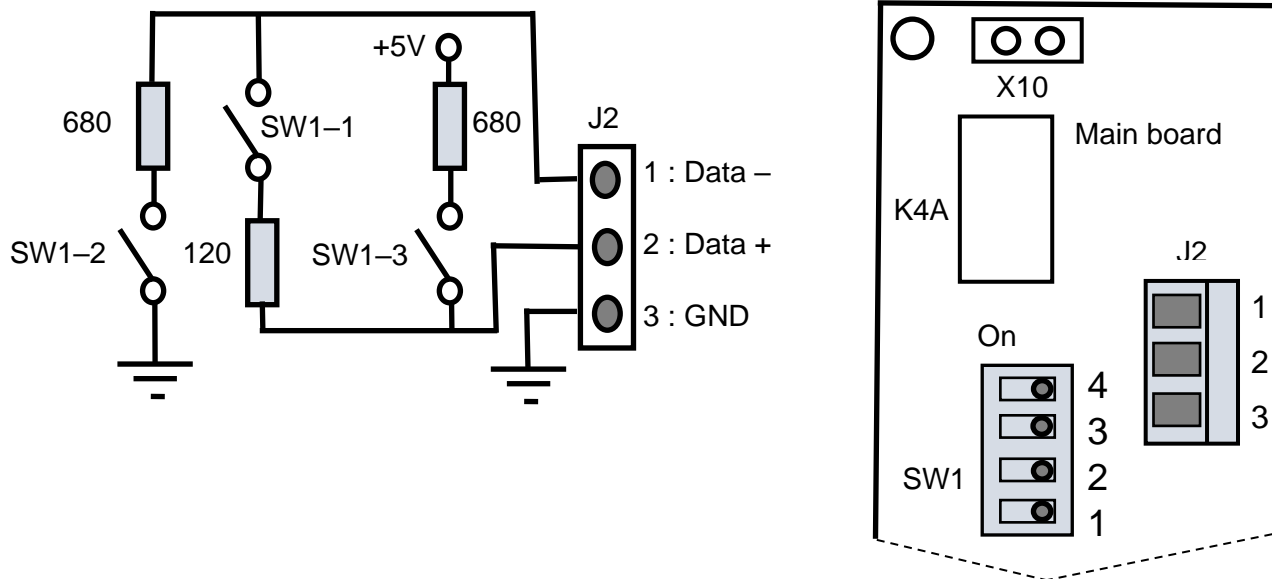

## 3.6.8 MODBUS RTU and BACNET MSTP Communication Parameters

	Modbus RTU	Bacnet MSTP
Speed of communication	2400 / 4800 / 7200 / 9600 (default) / 14400 / 19200 / 28800 / 38400 / 57600 / 115200 / 230400	
Packet size	8 bits	
Parity Bit	Not	
Stop bit	2	1
Timeout response	5000ms (5sec)	
Time between requests (After a response received)	Min. 100ms	Standard

# ElectroVap® STEAM BATH

## 3.6.9 BACnet Protocol Implementation Conformance Statement

**Vendor Name:** Armstrong International

**Product Name:** Armstrong Motherboard

**Product Model Number:** see plate.

**Application Software Version:** 1      **Firmware Revision:** 1      **BACnet Protocol Revision:** 19

**Product Description:** Mother board with integrated automate functions.

**BACnet Standardized Device Profiles Supported (Annex L):** BACnet Application Specific Controller (B-ASC)

**BACnet Interoperability Building Blocks Supported (Annex K):** Minimal required by B-ASC devices

**Segmentation Capability:** No segmentation

**Standard Object Types Supported:** Available objects are listed in the object table; each object has the minimal requirement by the standard.

The main device objectID is by default 0x02000000 + vendor ID x 1000 + ThisStationAddress, can be set in menu.

**Data Link Layer Options:** MS/TP master (Clause 9), baud rate(s): 9600,38400, and others (see table above).

**Device Address Binding:** No

**Networking Options:** none

**Character Sets Supported:** ISO 10646 (UTF-8)

For more information on the application of the communication protocol, please contact your vendor.

### 3.6.10 Communication protocol for RS 485 interface - MODBUS and BACNET

Modbus Register Address	Bacnet Object Class / instance # / ID (hex)			Description	Value
10001	BI	0	00C00000	Contactor	1 = production -- 0 = no production
10002	BI	1	00C00001	High-level detection	1 = reached-- 0 = no reached
10003	BI	2	00C00002	High limit switch	1 is opened -- 0 is closed
10004	BI	3	00C00003	Fill valve	1 = filling – 0 = no filling
10005	BI	4	00C00004	Drain valve	1 = draining -- 0 : no draining
10006	BI	5	00C00005	relay X10 (term. 3-4): Blower pack / remote ON/OFF, service, default	1 : relay ON -- 0 : relay OFF
10007	BI	6	00C00006	maintenance returns	1 is ON -- 0 is OFF
10008	BI	7	00C00007	Alarm returns	1 is ON -- 0 is OFF
1	BO	0	01000000	On/Off BMS command	1 = ON : Start requested / 0 = Off: Stop Unit
2	Bv	1	01400001	Not used	Not used
3	Bv	2	01400002	option 1 (with SB card 8 relays)	1: ON -- 0: OFF
4	Bv	3	01400003	option 2 (with SB card 8 relays)	1: ON -- 0: OFF
5	Bv	1	01400001	option 3 (with SB card 8 relays)	1: ON -- 0: OFF
6	Bv	2	01400002	option 4 (with SB card 8 relays)	1: ON -- 0: OFF



# ElectroVap® STEAM BATH

30001	AI	0	00000000	Type unit	1: Steam Bath, 2: ELMC,3: CMC, 13: EHU 750
30002	AI	1	00000001	Register version	1
30003	AI	2	00000002	Current	10 x (A)
30004	AI	3	00000003	Run status	0: Idle 1: Steam Gen 2: End of season 3: Failure 4: Manual drain 5: Maintenance
30005	AI	4	00000004	maintenance counter	(Hours)
30006	AI	5	00000005	time	(Hours)
30007	AI	6	00000006	time before end-of-season draining	(Hours)
30008	AI	7	00000007	Control Signal value	10 x V or 10 x mA gold %
30009	AI	8	00000008	Temperature (maintenance option or SB)	(C)
30010	AI	9	00000009	Error code	0: Normal operating 1: P1 Error 2: P2 Error 3: P3 Error 4: P4 Error 5: P5 Error 6: P6 Error 7: P7 Error 8: P8 Error 9: P9 Error 10: First inspect. 11: Overdue service
30011	AI	10	0000000A	type of water	1: Tap water 2: Softened water3: Partial DI water 4: DI water
30012	AI	11	0000000B	type of control	20:On/Off 21: Digital Ctrl 22: Digital Sensor 23: 0-10V CTRL 24:0-5V CTRL 25:0-20mA CTRL 26:0-10V Sensor 27:0-5V Sensor28:4-20mA Sensor 29: Temp Sensor
30014	AI	13	0000000D	Application	(%)
30015	AI	14	0000000E	steam production	10 x (Kg/hr)
40004	Av	3	00800003	End-of-season (EOS)	(hours) mini - 1 and maxi - 168
40005	Av	4	00800004	Steam capacity limit	(%) mini - 20% and maxi - 100%
40006	Av	5	00800005	RH or demand value (digital or digital probe).	( %) mini - 1 and maxi - 100
40007	Av	6	00800006	RH set point	( %) mini - 1 and maxi - 100SB: (C) 25 to 55
40008	Av	7	00800007	Not used)	Not used
40009	Av	8	00800008	Not used	Not used
40010	Av	9	00800009	maintenance interval	(hours / 100) mini - 1 and maxi - 200
40011	Av	10	0080000A	production adjustment	Draining - 1 or evaporation - 2
40012	Av	11	0080000B	anti-foam drain time	mini - 0 sec and maxi 15 sec

# ElectroVap® STEAM BATH

## 3.7 Wiring diagram

ELMC 5-10 SB, Up[V] - 1x200-240V 50-60Hz

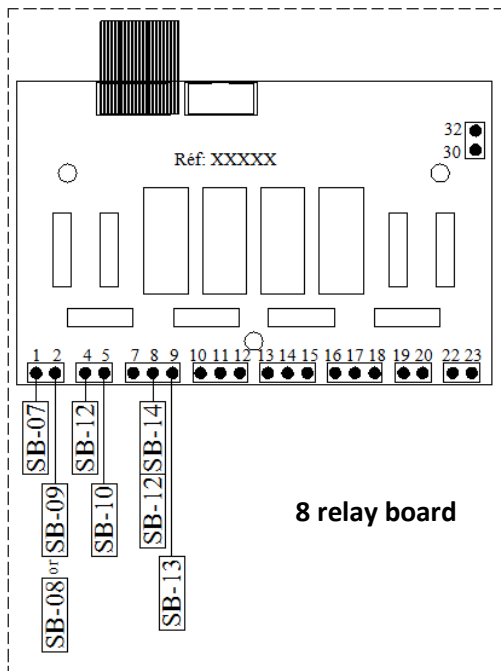
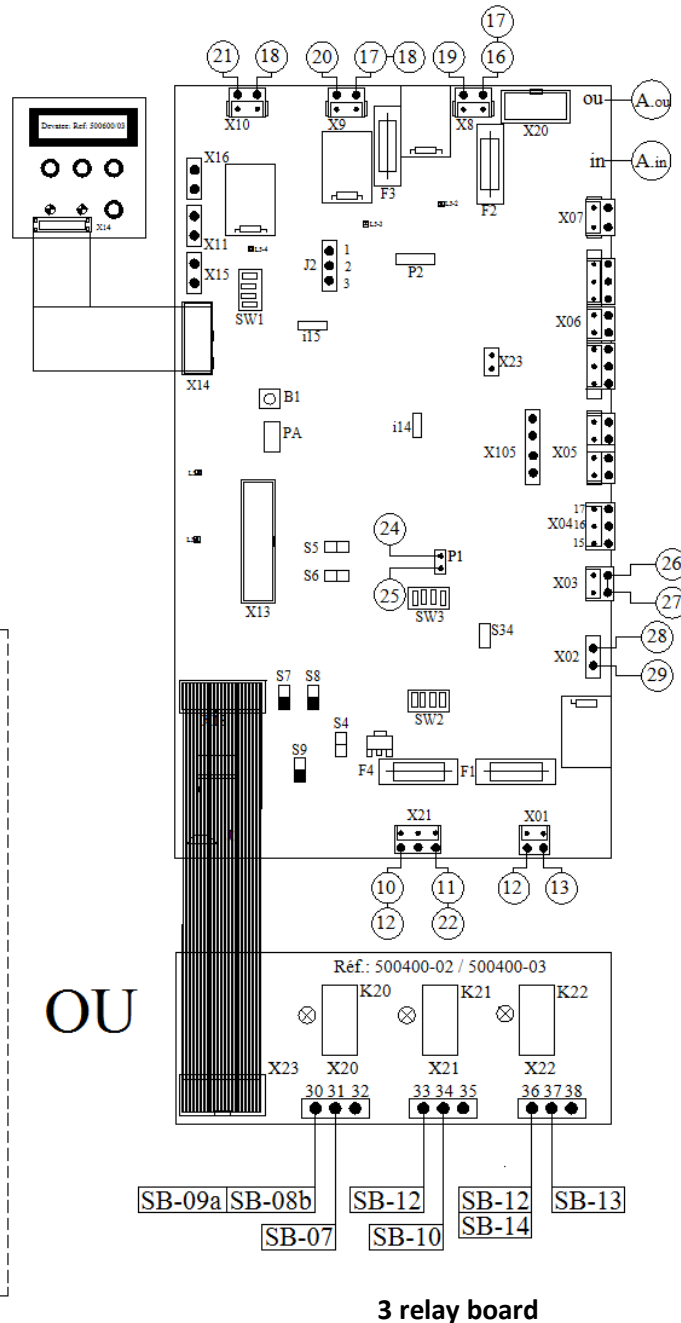
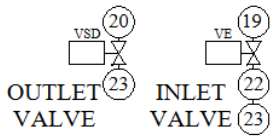
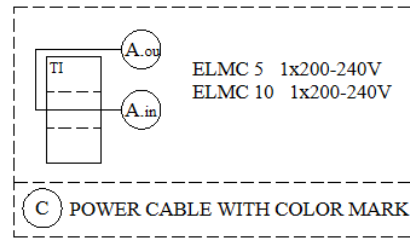
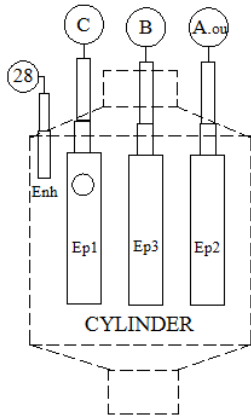

# ElectroVap® STEAM BATH

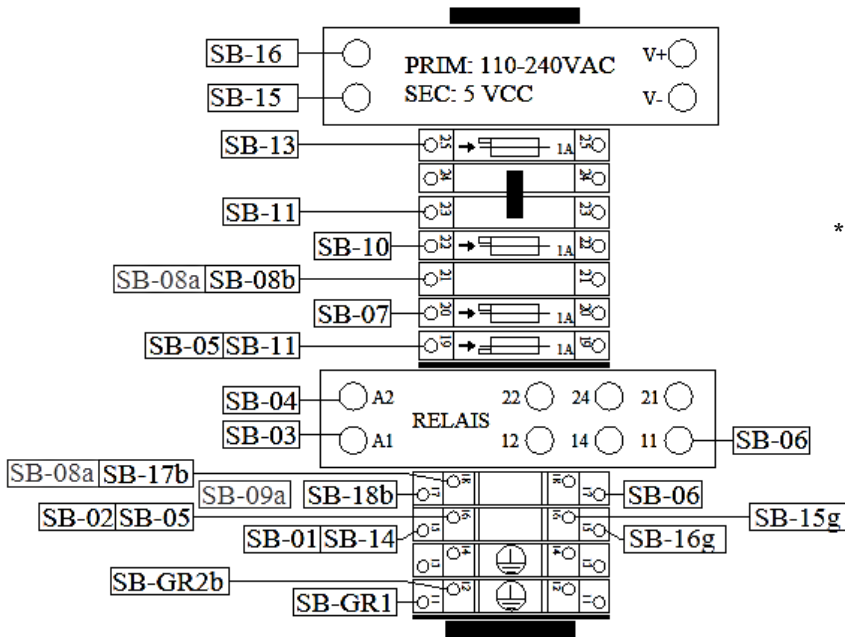

\*If option Remote Control

\*If option Bluetooth Gateway kit

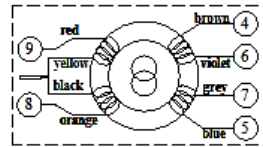

Power Switch

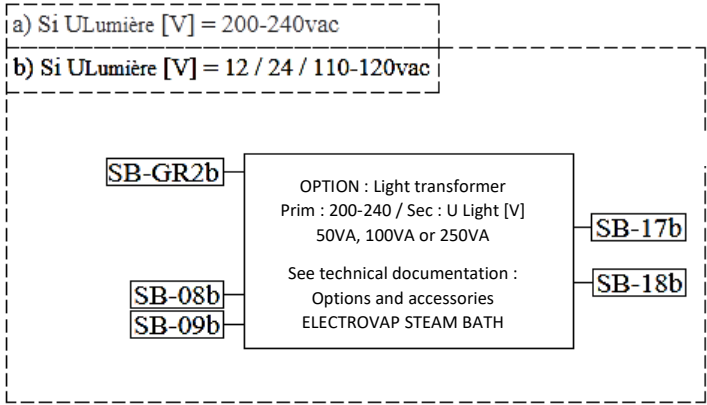
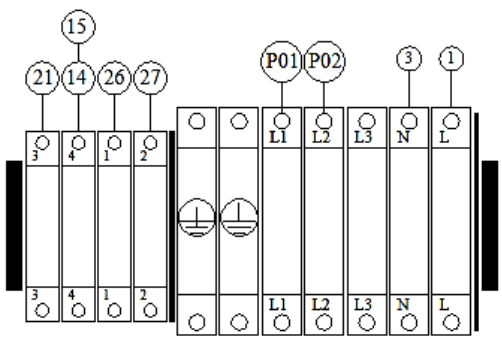
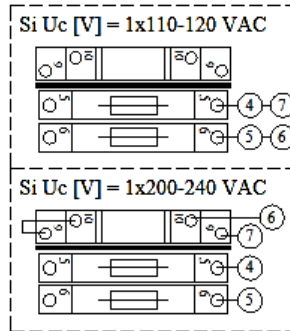
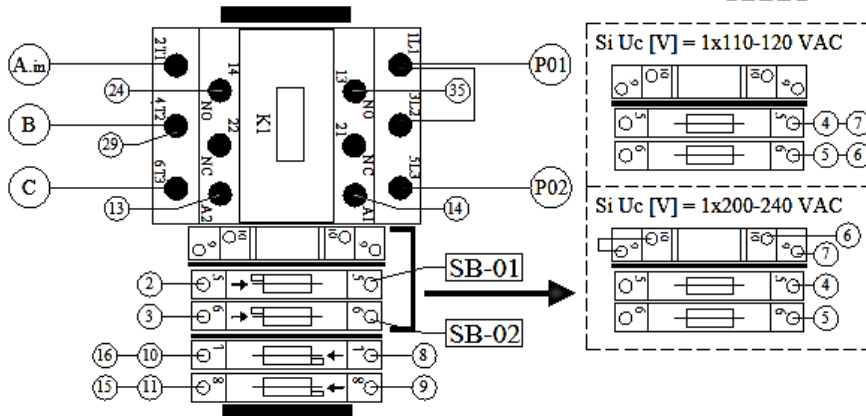
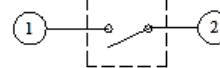

# ElectroVap® STEAM BATH

ELMC 5 à 30 SB, Up[V] - 3x200-690V 50-60Hz

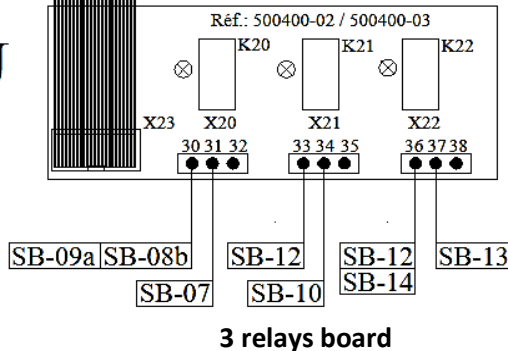
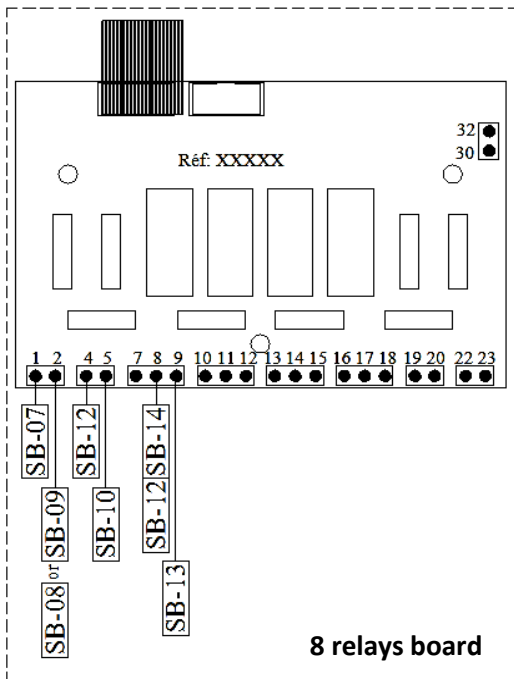
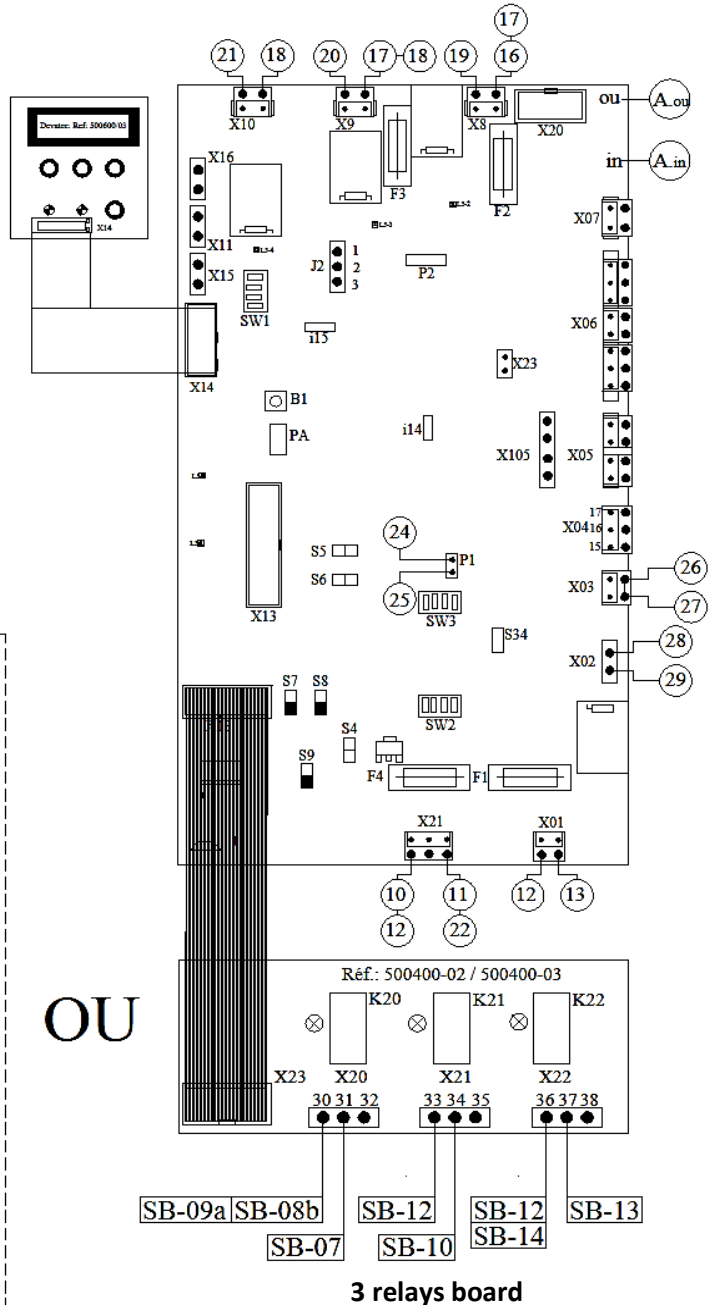
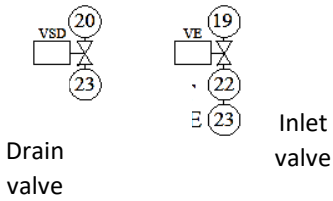
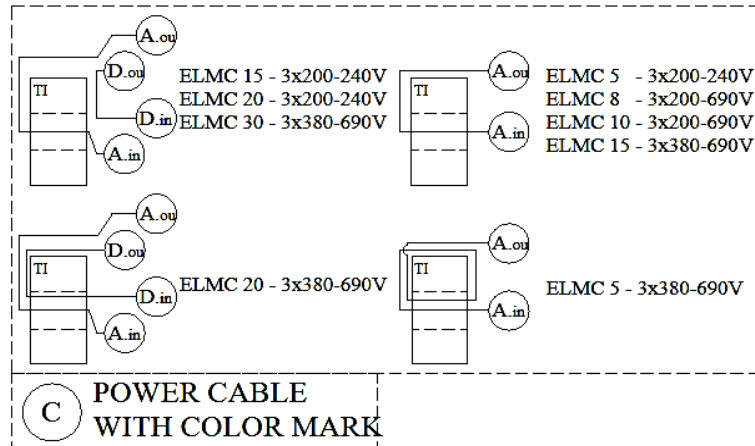
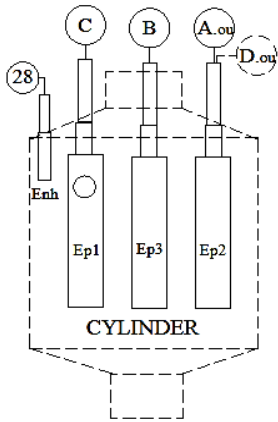

# ElectroVap® STEAM BATH

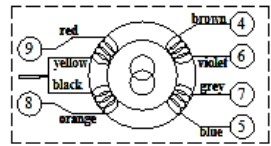
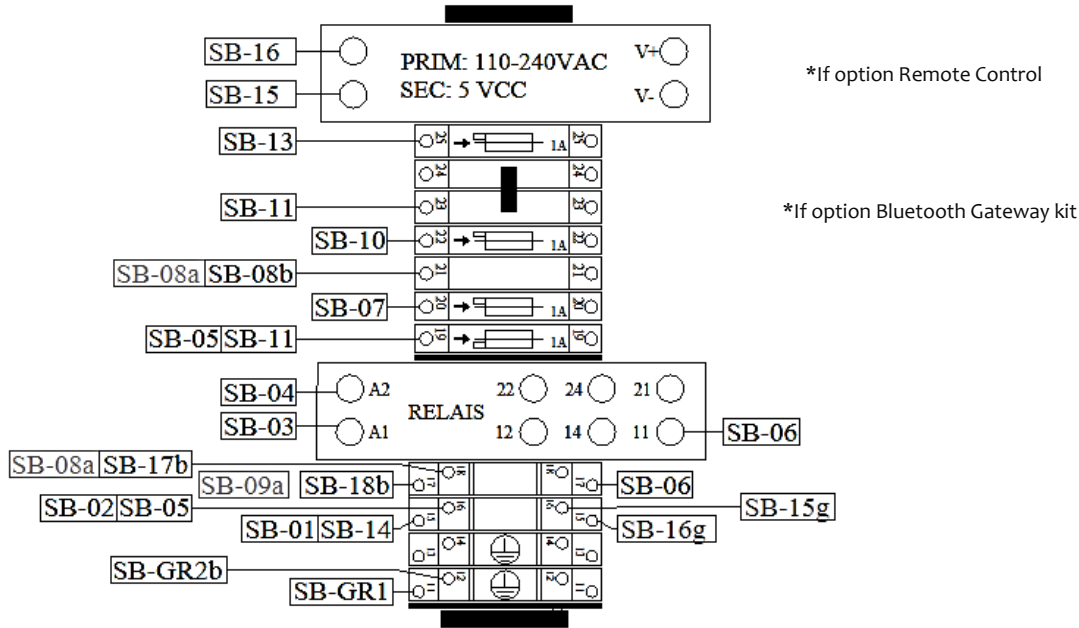

Power Switch

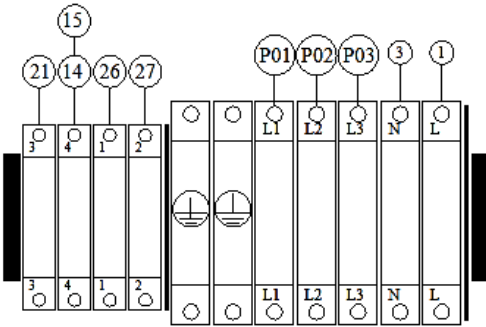
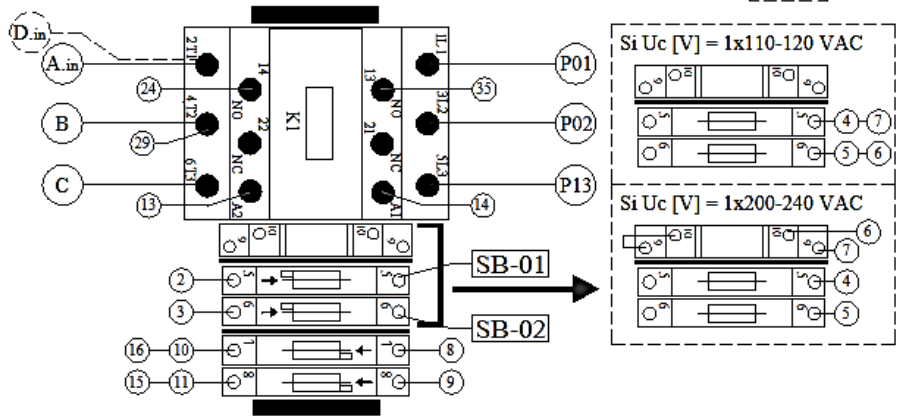
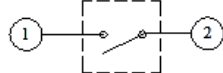

- a) Si ULumière [V] = 200-240vac
- b) Si ULumière [V] = 12 / 24 / 110-120vac

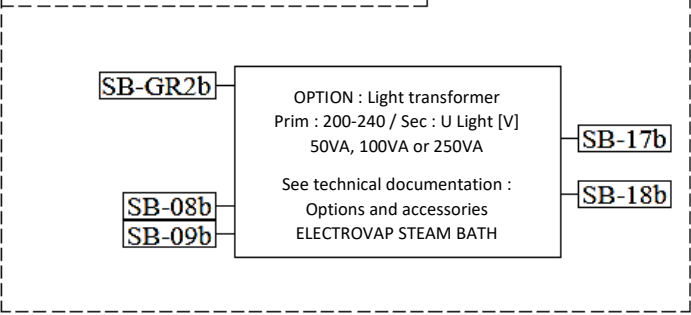

# ElectroVap® STEAM BATH

ELMC 40 à 60 SB, Up[V] - 3x200-690V 50-60Hz

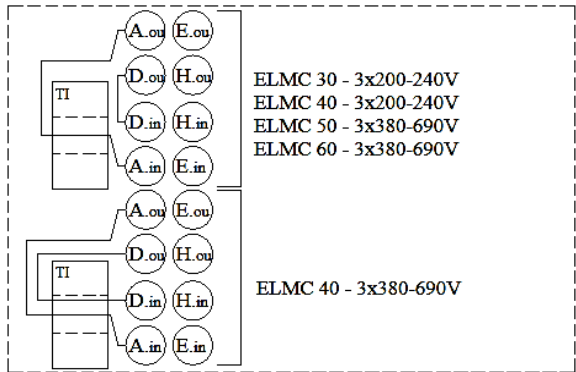

(G) (C) POWER CABLE WITH COLOR MARK

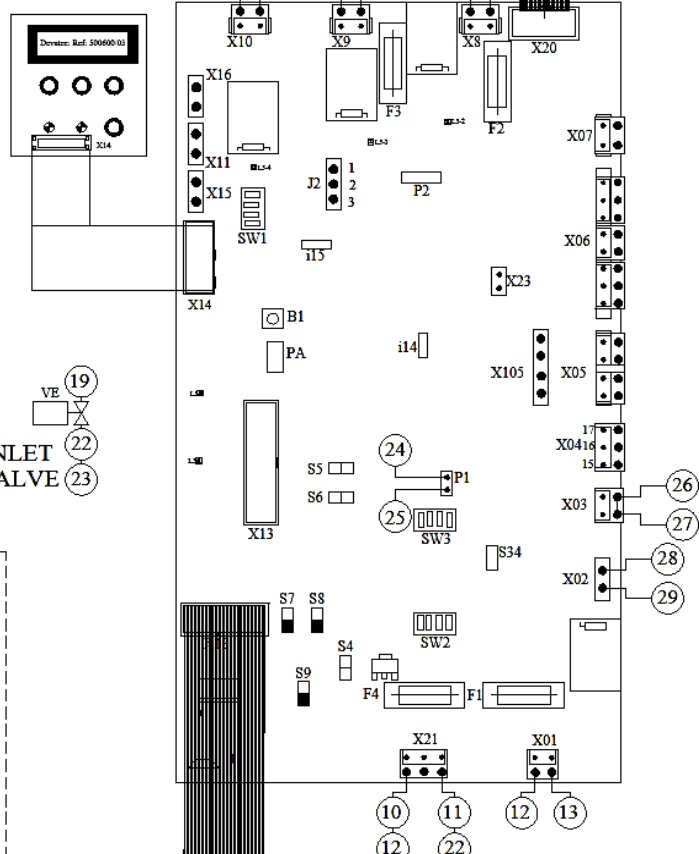
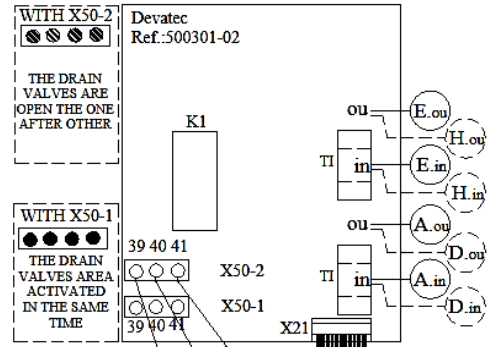
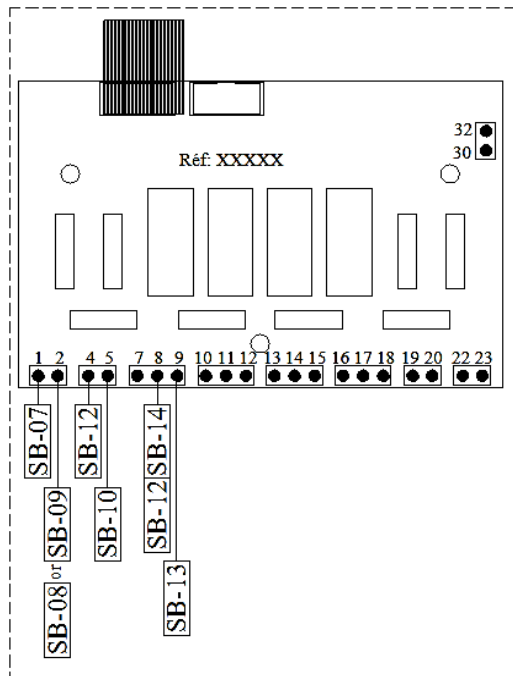
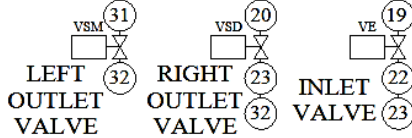
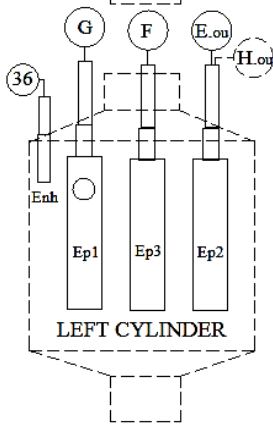
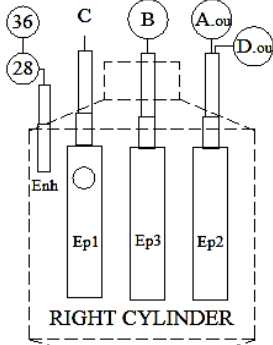

OR

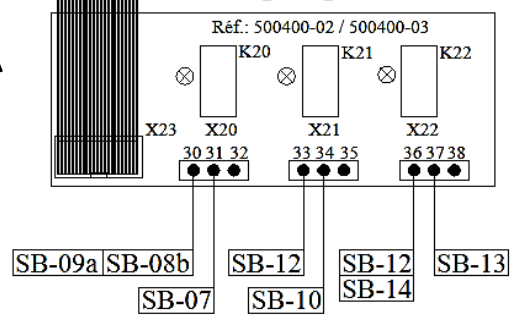

# ElectroVap® STEAM BATH

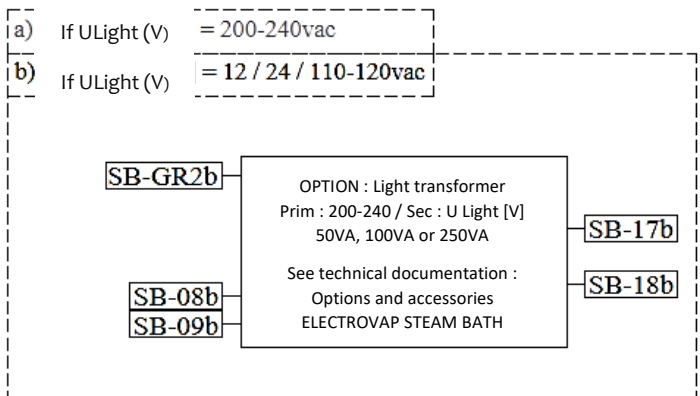
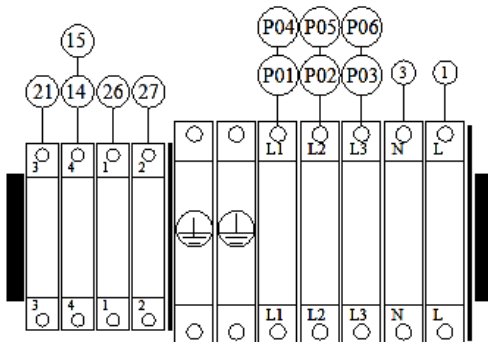
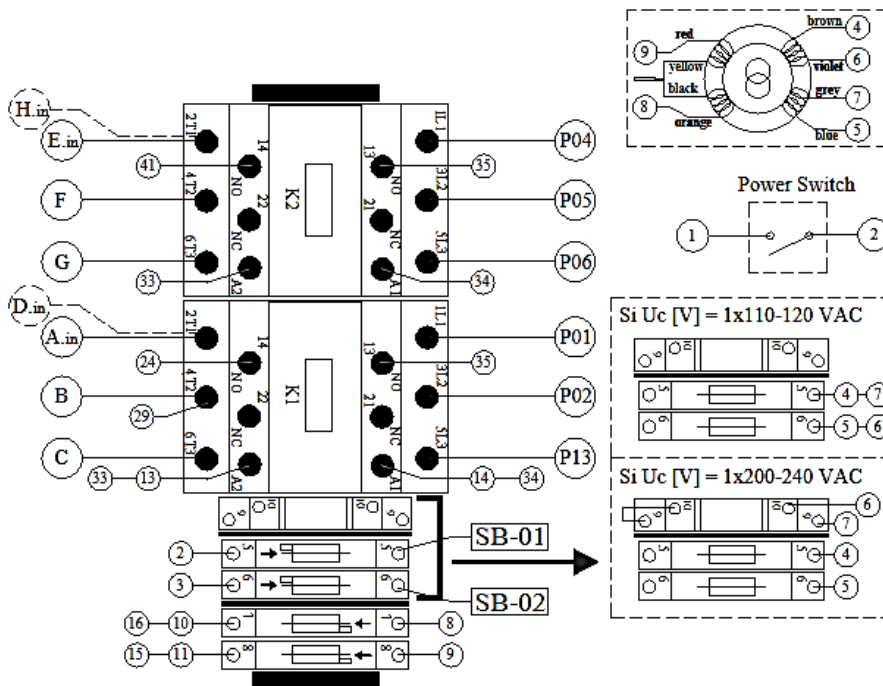
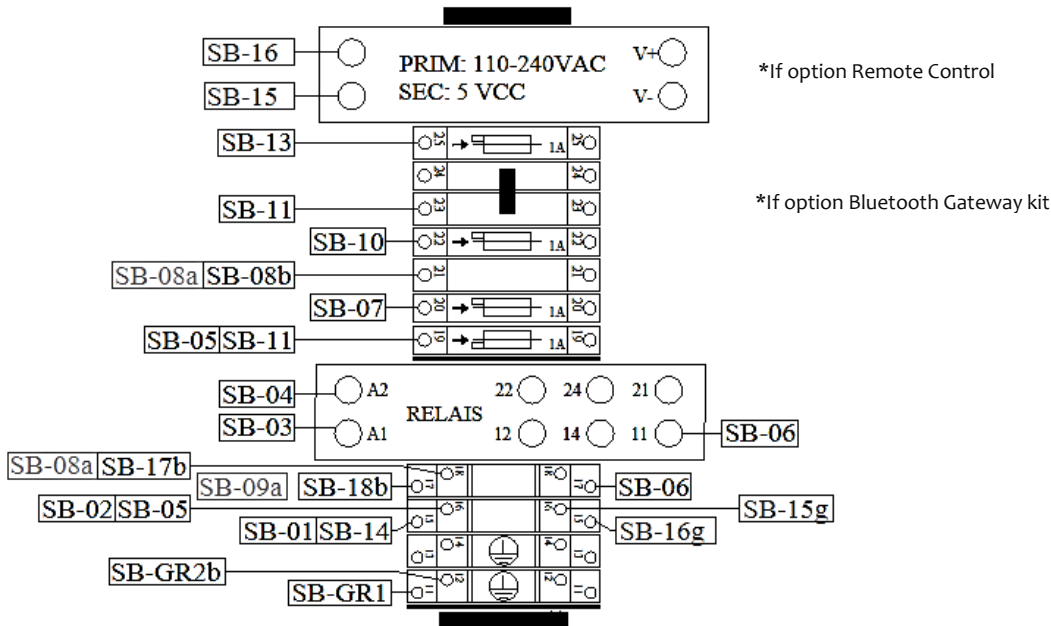

# ElectroVap® STEAM BATH

ELMC 90 SB, Up[V] - 3x200-690V 50-60Hz

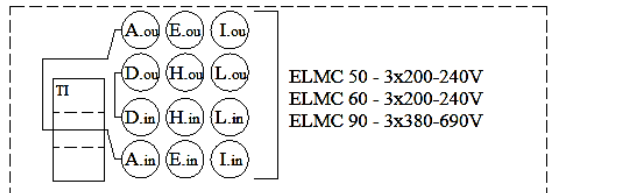

K G C POWER CABLE WITH COLOR MARK

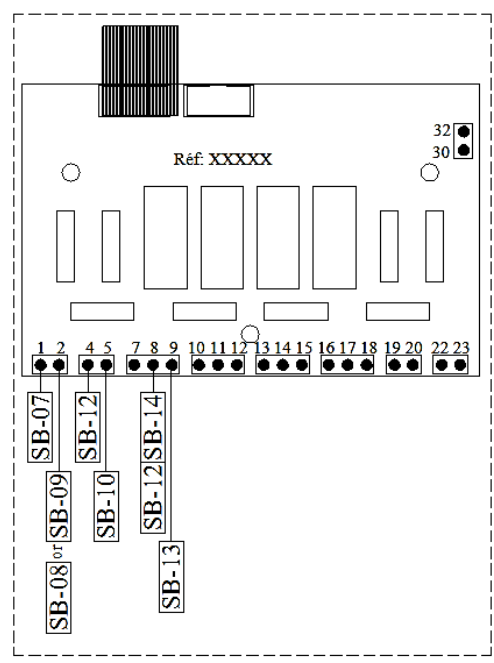
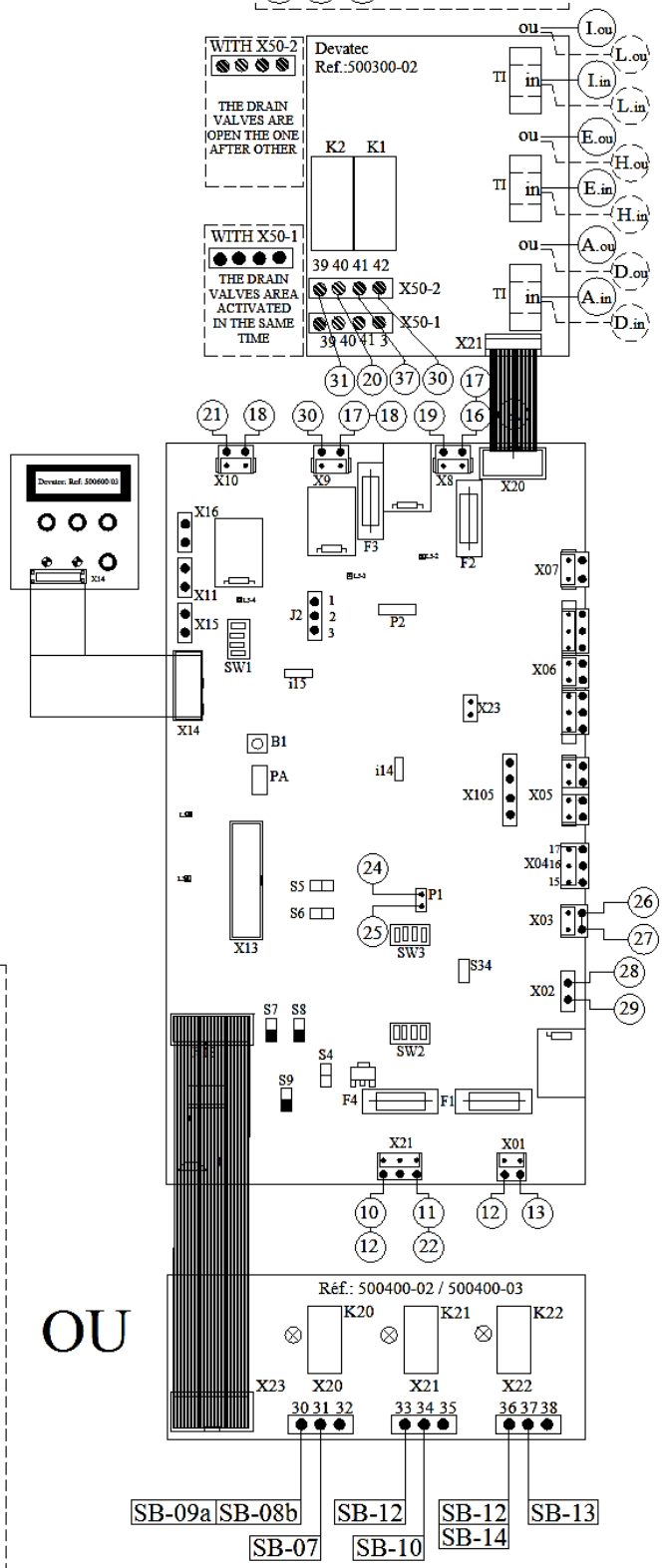
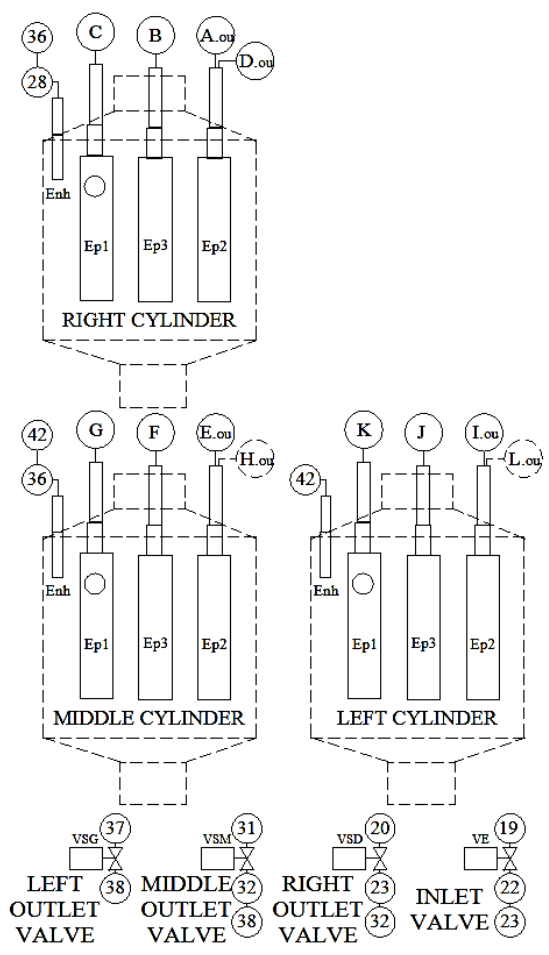



# ElectroVap® STEAM BATH

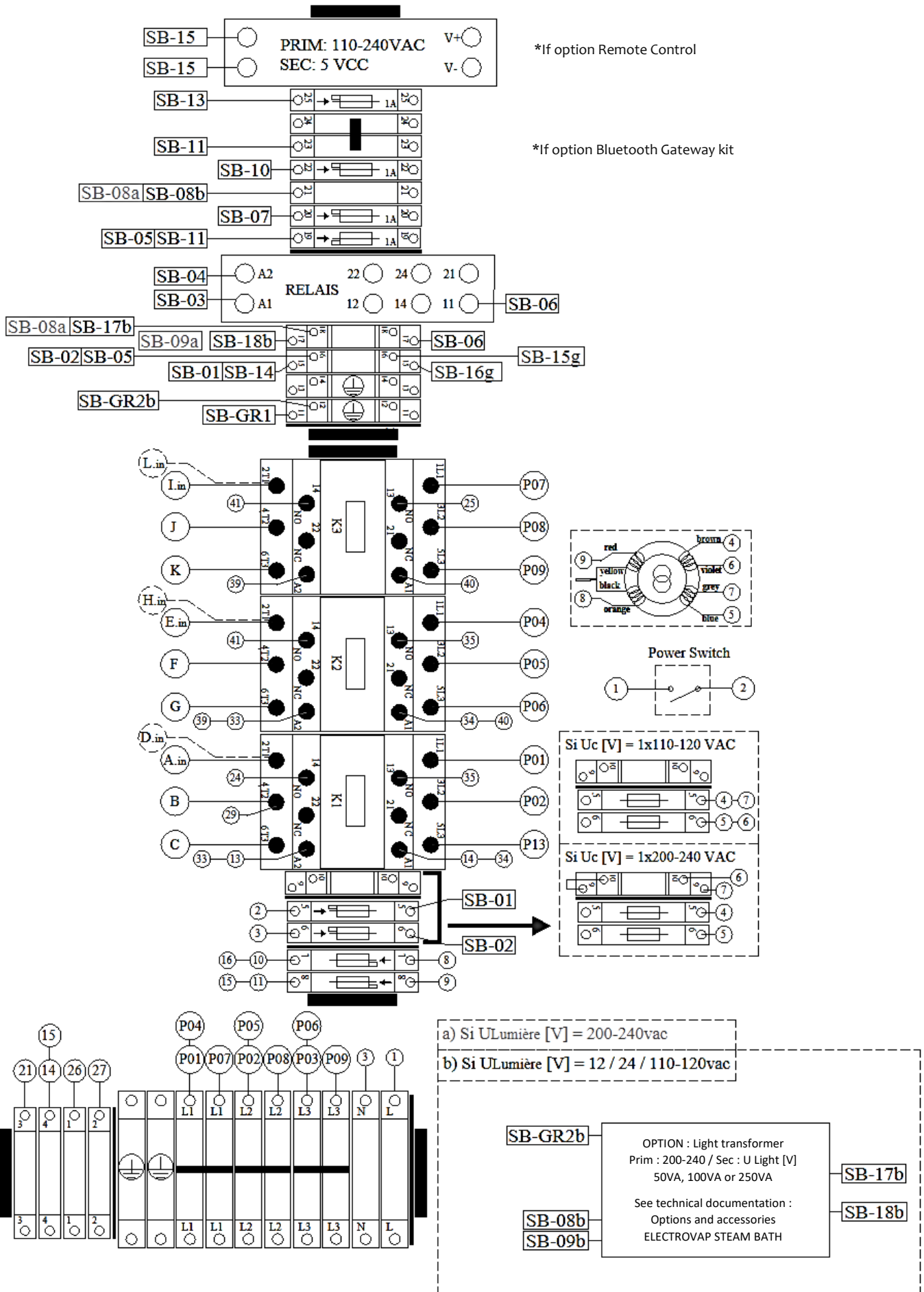

# ElectroVap® STEAM BATH

## 4 COMMISSIONING



Before operation, please check that your installation complies with the manufacturer's technical recommendations. Check all power cables electrical connections. Remove the blocking blue foam ring from the tank.

Marker 1: Validation & change menu button

Marker 2: Upward button

Marker 3: Downward button

Marker 4: Manual drain button for maintenance

Marker 5: LED = Steam production indication

- Open the main water supply valve.
- Switch on the main power supply (power and control voltages).
- Switch on the unit switch.
- If the unit asks you for a commissioning code, note the serial number on the nameplate and contact your agent to obtain this code.

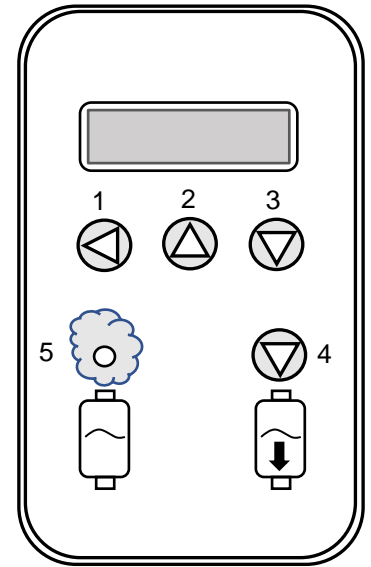

Fig. 4 Steam Generator display

- Enter your three-digit code by doing this:  
Press one of the keys 1, 2, 3 and the display will show you 0XX, with the flashing zero to eventually change it by pressing 2 or 3.  
Once arrived at your digit, validate it by pressing key 1 and your second digit flashes. Repeat the previous two operations to show the last two digits.

**Very important: do not forget to validate the last digit.**

- Enter water quality in the displayed menu.
- The device is ready to respond any production request.
- During steam production, the LED (5) lights up.

# ElectroVap® STEAM BATH

## 5 SYSTEM MANAGEMENT

### 5.1 USER INFORMATION (READ ONLY)

DEVATEC www.devatec.com		HUMIDIFIER CONFIGURATION	
INITIALISATION ELMC V XX.XX.XX			
HUMIDIFIER STATUS			
STEAM BATH ELMC xx XxXXXV			
STEAM PRODUCED XX.X lbs XX.X KG			
ACTUAL CURRENT XX. X A			
T°C HAMMAM: XX°C SET POINT: XX°C	TEMP.(°C) SENSOR		
STEAM DEMAND XX %	Normal operation	SAFETY (1-2) IS OPENED	Si 1 et 2) ouvert
STEAM DEMAND 0 %	If demand = 0%	TEMP.(°C) SENSOR FAULTY	See default message
DRAIN AFTER (HRS) XXX		NO DEMAND MODBUS STOP	If stop requested by: Remote control, Mobile application, Modbus or Bacnet
PRODUCT BEFORE CLEAN XXXXXX KG			
NEXT SERVICE DUE -XXXXX HRS			
HOUR METER XXXXX HR			
STEAM METER XXXXX KG			
ELECTRICAL POWER XXXX KW			
BACK TO THE BEGINNING			

# ElectroVap® STEAM BATH

## 5.2 STEAM GENERATOR STATUS MENU

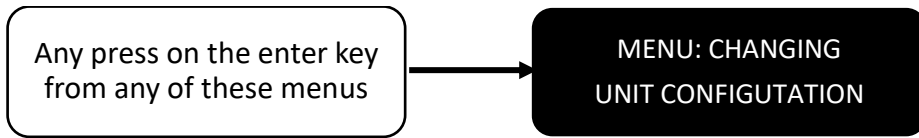

HUMIDIFIER  
CONFIGURATION

CONTROL SGNAL IN  
TEMP.(oC) SENSOR

TOTAL HOURS RUN  
XXXXXXXX HR

TOTAL STEAM PROD  
XXXXXXXX KG

WATER QUALITY  
XXXXXXXXXXXX

CYLINDER USED :  
XXXXXXXXXXXX

POWER SUPPLY (V)  
XxXXX

MAXIMUM POWER  
INSTALL XX.X KW

BACK TO THE BEGINNING

# ElectroVap® STEAM BATH

## 5.3 CHANGE SETTINGS MENU

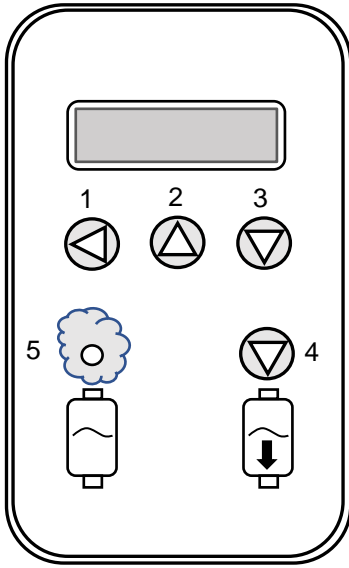

Procedure to enter the access code:

- Press the "1" key: the first cross flashes.
- Press the "2" key to increase the digit or the "3" key to decrease it.
- Once you have reached the desired digit of the code, press the "1" key to validate it: the 2nd cross flashes.
- Proceed in the same way for the following digits, and do not forget to validate the code by pressing the "1" key.

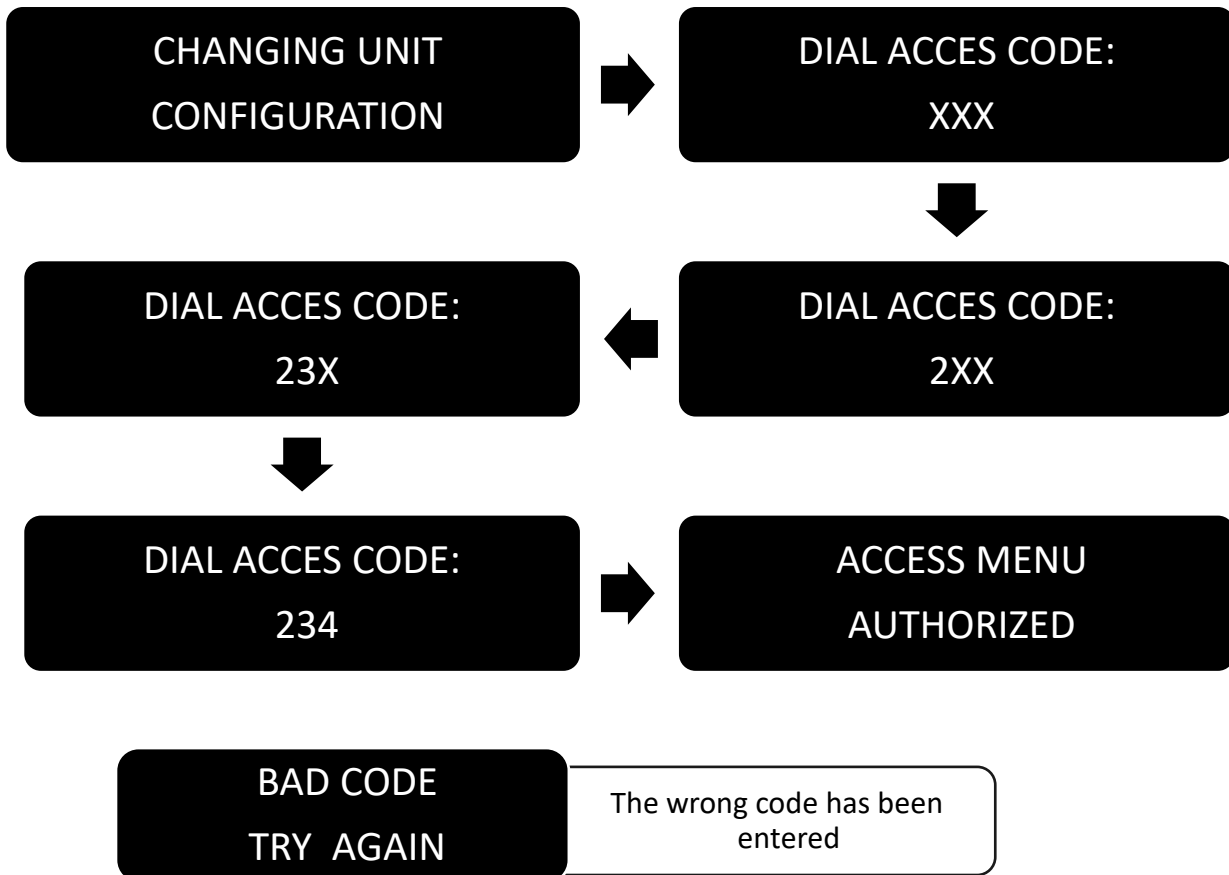

# ElectroVap® STEAM BATH

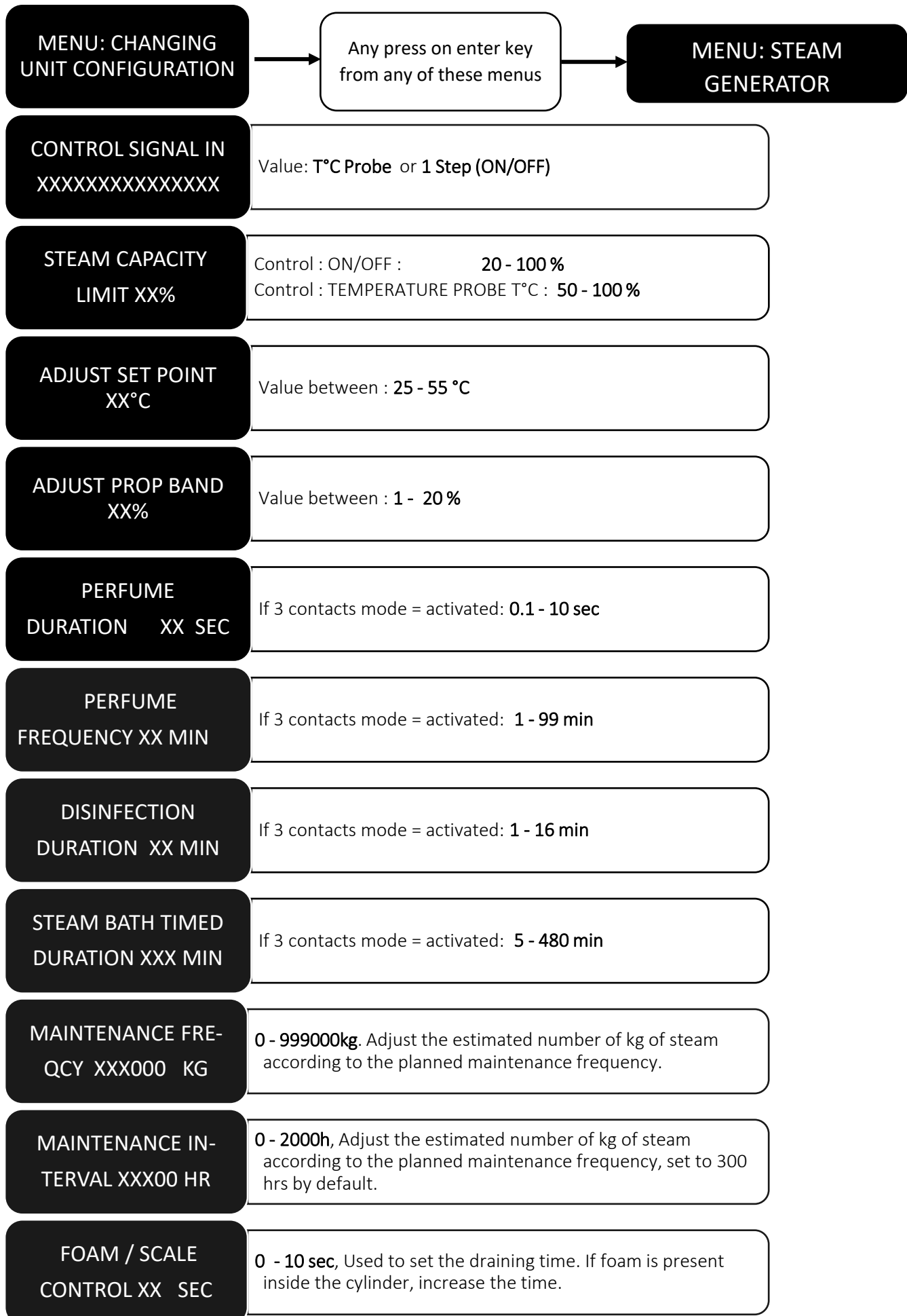

# ElectroVap® STEAM BATH

POWER OFF IF DRAINING : XXX	YES or NO, Cut the contactor during the draining phases.
ADJUST STEAM BY: KG XXXXXXXXXXX	BY DRAINING or EVAPORATION (required with demineralized water).
CYLINDER SELECT : XXXXXXXXXXXXXXXX	CLEANABLE (EV) eau de ville, CLEANABLE (ED) eau déminéralisée, CLEANABLE (EA) eau adoucie.
IDENTIFICATION OF ELMC XXX	<b>VALUE between 1 and 32:</b> Identifies humidification when it is connected to a communication Modbus
SPEED DATA XXXX00b/s	Speed of communication between the ELMC and the BMS: 2400/4800/9600/14400/19200/28800/38400/57600/115200 /230400 b/s
DEVICE INST. ID XXXXXXXXX	<b>0 to 4194303</b> , Entering an out-of-limit value causes a return to the default value. (« vendorID x 1000 + ThisStationAddress »). It is mandatory to validate the 7 digits to validate the value change.
COM PROTOCOL XXX	• Values: MODBUS RTU 8-N-1, MODBUS RTU 8-N-2, • BACNET MS/TP
SETTING TEMP °C WATER 65°C XXX	<b>VALUE: NO:</b> Not used with Steam Bath
DRAINING AFTER SHUT DOWN ? XXX	YES or NO, drains the unit after a defined stop time.
DRAIN AFTER (HRS) XXX	1 to 72 hours (if the previous one on YES)
BACK TO THE BEGINNING	

# ElectroVap® STEAM BATH

## 5.4 MAINTENANCE ALERTS

**INSPECTION DUE  
50h - SEE MANUAL**

**This message will appear 50 Hrs after the first start.**  
It is then necessary to check the correct tightening of electrical and hydraulic connections (steam pipe, drain system, water supply...). The unit is not stopped

**SERVICE DUE  
SEE MANUAL**

Means that maintenance must be carried out.  
The unit is not stopped

**SERVICE OVERDUE  
SYSTEM SHUTDOWN**

This message appears 100h after the **SERVICE DUE SEE MANUAL** message.  
In this case, the cylinder is drained, and the unit is stopped. Maintenance must be carried out.

**REPLACE CONTACT-  
ORS 10000 hr RUN**

After 10,000 hours of operation, it is recommended to replace the contactor. The unit is not stopped

**TO CARRY OUT A RESET FOR THE ABOVE MESSAGES,  
FOLLOW THIS PROCEDURE:**



- Switch the unit to drain by pressing the manual drain button (4).
- Press button 3 for at least 5 seconds.

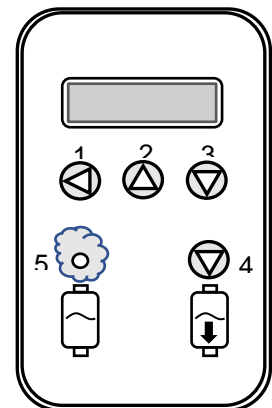



# ElectroVap® STEAM BATH

## 5.5 DEFAULT MESSAGE

**SEE: CONTACTOR  
OUT OF ORDER P1**

### **Meaning:**

The signal passing through the contactor is OFF when it should be ON. The contactor no longer works and there is no steam production.

### **In this case:**

When this message appears, the cylinder is drained, the general fault contact is activated, and the unit is then stopped.

### **Causes and remedies:**

1. Check the F1 (2A) fuse on the main map.
2. Check the connection of the connector wires of the contactor
3. Make sure the X01 (wire 12 and 13) is well connected to the map
4. Change the faulty contactor

**SEE: CONTACTOR  
BLOCKED P2**

### **Meaning:**

The signal passing through the contactor is ON when it should be OFF. The contactor has a defect and produces steam when it should not.

**CAUTION : switch off the steam generator before any handling**

### **In this case:**

When this message appears, the cylinder is drained, the general fault contact is activated, and the unit is then stopped.

### **Causes and remedies:**

1. Turn off the device
2. Check the condition of the contactors visually
3. Make sure the X01 (wire 12 and 13) is well connected to the main board
4. Change the faulty contactor

**LEAKAGE: INLET  
WATER VALVE P3**

### **Meaning:**

The water inlet valve is defective, the high level is not reached after 20 minutes.

### **In this case:**

When this message appears, the cylinder is drained, the general fault contact is activated, and the device is not stopped.

### **Causes and remedies:**

1. Make sure the water supply faucet is open
2. Check for water in the cylinder
3. Change the water inlet valve

# ElectroVap® STEAM BATH

NO INLET WATER  
P4

**Meaning:**

The water supplement of the cylinder is not done properly

**In this case:**

When this message appears, the cylinder is drained, the general fault contact is activated, and the device is not stopped.

**Causes and remedies:**

1. **Check water supply.** The pressure must be constant and between 2 and 8 bar. If in doubt, install a pressure regulator set at 2 bar on the supply pipe. Also check the condition of the water inlet valve, the electrical connection and the condition of fuse F2 (2A). Change the valve and fuse if defective.
2. **Check for proper condensate drainage.** Must absolutely be drained, otherwise it will accumulate in the steam hose, creating water projections and pressure rise in the tank, preventing the unit from being filled.
3. **Verify that the bleed valve is properly closed.** A piece of scale can block the valve closure and cause a leak, preventing proper filling of the unit.
4. **Electronic issue.** Replace the main board and check that there is no steam or water flow in the electrical compartment.

SEE : DRAIN  
CIRCUIT P5

**Meaning:** Draining is not done properly

**In this case:**

When this message appears, the cylinder is drained, the general fault contact is activated, and the device is not stopped.

**Causes and remedies:**

1. Check the condition of the F3 fuse, if defective, change it.
2. Clean the draining circuit, in case a piece of limestone blocks.
3. Check how the coil valve works, if defective, change it.

# ElectroVap® STEAM BATH

**CLEAN: CYLINDER  
+ DRAIN VALVE P8**

**Meaning:** Draining is not properly done

**In this case:**

When this message appears, the cylinder is drained, the general fault contact is activated, and the device is stopped.

**Causes and remedies:**

1. The drain system is clogged. Press the manual drain button, and check for the proper flow of water. Then clean the inside of the cylinder. Check if there is limestone in the valve.

**TEMP.(βC) SENSOR**

Connection problem between the temperature sensor and connector X04 (15-16-17) on the main board  
Or Wrong configuration of the dip switches

S4 , S5, S6



**TEMP. (°C) SENSOR  
FAULTY**

Defective probe (thermal shock) or incorrect probe installation



**TO CARRY OUT A RESET FOR THE ABOVE MESSAGES,  
FOLLOW THIS PROCEDURE:**

- Switch the unit to drain by pressing the manual drain button (4).
- Press button 3 for at least 5 seconds.

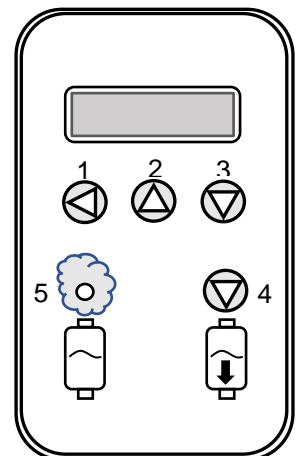

# ElectroVap® STEAM BATH

## 6. MAINTENANCE

### 6.1 GENERAL INFORMATION

#### Periodic checks

- After 1 hour of operation, check for no water leaks in the middle and foot of the cylinder.
- After 50 hours of operation, check the condition of the cylinder. Make sure no arcing or flicker occurs between the electrodes during operation.

Check the filter inside the water inlet valve as well as the drain system.

Please re-examine all the power cable connection terminals, as well as the clamps of the various pipes (steam, drain, inside the wet part).

**WARNING!** Tighten the clamps when the cylinder is cold.

- After a year of operation, please check the condition of your steam hose, water drain and the internal pipes of the unit. If some pipes seem damaged, it is essential to change them. Please tighten all connection terminals.

#### Warnings

After a prolonged use or with the use of high TH water, may be solid deposits on the electrodes which can increase the concentration of water.

If electrical arcs appear inside the cylinder, your steam generator works under abnormal conditions and these arcs can cause:

- A significant heat increase that could overheat the plastic and even melt it, causing a hole and then a leak into the unit.
- A disjunction of the device due to a high intensity created by the electrical arcs.
- Premature deterioration of heating electrodes.
- Burning of electrodes power cables.

#### In case of electric arcs

Check any points in case electrical arcs appear inside the cylinder:

- If your water is running with softened water, make sure your softener does not release salt into the appliance's water supply pipes.
- Make sure the drain valve is working properly and maintain it.
- Check F3 drain valve fuse on the main board.



The steam generator has powered electrical components, and the cylinder has heated elements. Therefore, all work must be carried out by qualified and competent personnel. Before working on the cylinder, make sure that the steam generator is switched off.

# ElectroVap® STEAM BATH

## 6.2 STEAM CYLINDRE CLEANING

### ESTIMATED CYLINDER MAINTENANCE CURVE

X – steam demand

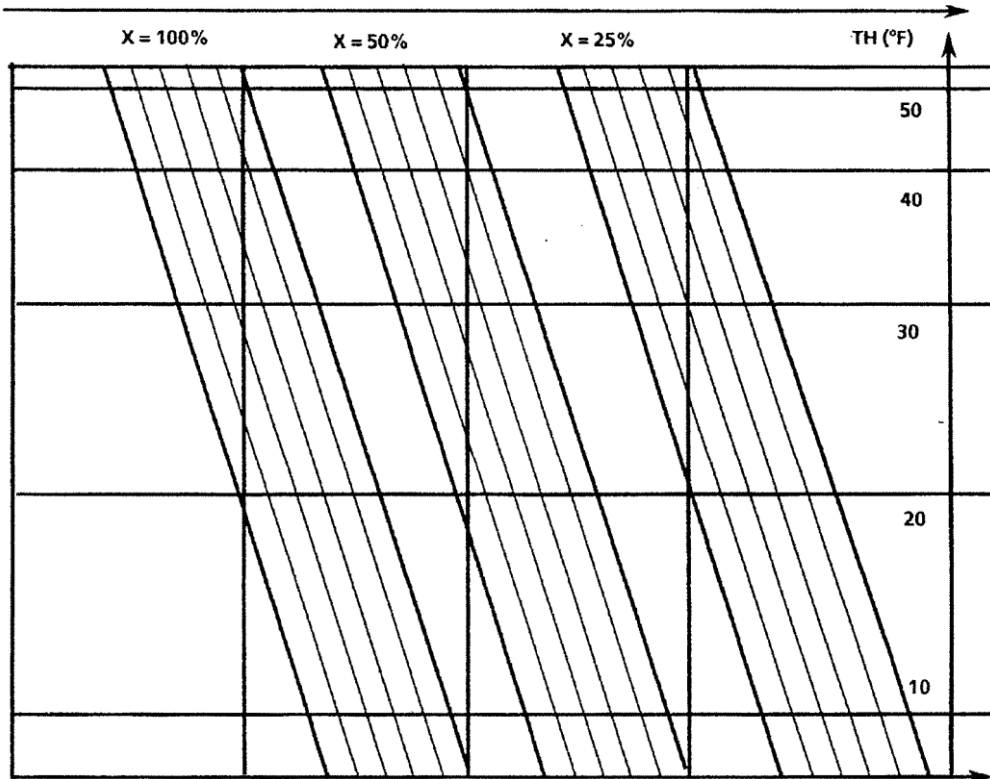

Exemple : Pour un générateur fonctionnant à 100% de sa capacité, utilisant de l'eau avec un TH20, le cylindre vous devra être nettoyé ou changé après 800-900 heures de fonctionnement :

- La dureté de l'eau est exprimée en degré français. La valeur ainsi exprimée fait référence au titre hygrométrique de l'eau (TH).
- La qualité de l'eau est à préciser lors du choix de votre appareil afin d'adapter le cylindre à votre type/ qualité d'eau utilisée, permettant un fonctionnement optimal de votre générateur.

### CHANGEMENT D'ÉLECTRODE

	Longueur originale	
Type	ELMC 5–15 SB	ELMC 20-90 SB & ELMC 10 SB MONO
Longueur [mm]	160	250

Les électrodes doivent être changées lorsque leur longueur est inférieure à 1/3 de la longueur d'origine.

Les ElectroVap® STEAM BATH sont équipés en standard de cylindres nettoyaables qui peuvent être démontés.

# ElectroVap® STEAM BATH

## 6.3 CYLINDER CLEANING METHOD

- **Drain the cylinder** by pressing the drain button and wait until the cylinder is completely empty. The message "DRAINING CYCLE OVER" appears.
- **Turn off power** of the power circuits (in the general electrical cabinet) and control system located on the front of the device.
- **Remove the door from the hydraulic compartment, remove the power cable connectors and water level sensor (1 and 2).** Then loosen the clamp to disconnect the steam outlet hose (3 and 4).
- **WARNING! Risk of burns.** If the drain is recent, the steam cylinder is still burning. Therefore, wait for it to cool down.
- **Lift the cylinder up** by pressing down on its base to release it from the foot of the drain valve.
- **Remove the top of the cylinder from the retaining clip** and remove it from the hydraulic compartment.
- Please tighten the steam hose slightly on the cylinder, **only when the cylinder is cold, to avoid deformation.**

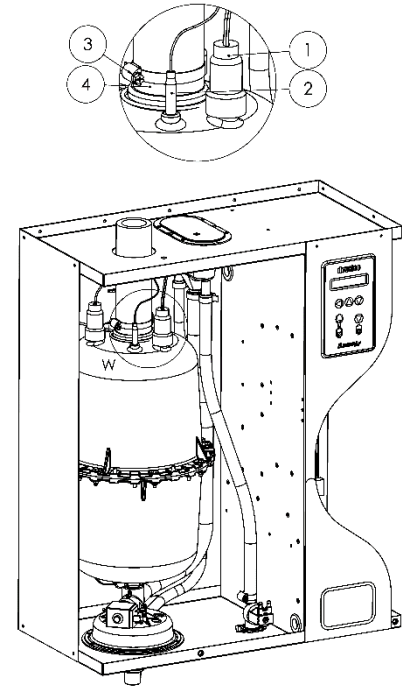

## 6.4 CYLINDER CLEANING METHOD

- After removing the cylinder, mark the two half-cylinders (1) at once.
- Remove the nuts and screws holding with two keys of 8 (2), open the cylinder. Remove the strainer and seal, then clean them (3).
- Clean the electrodes, the brace, and the inside of the cylinder's bodies by scraping the limestone (it is possible to use passed acid for power electrodes) (4).
- Rinse the electrodes, the bodies of the cylinder, the brace. Do not forget to clean the strainer in the cylinder foot.

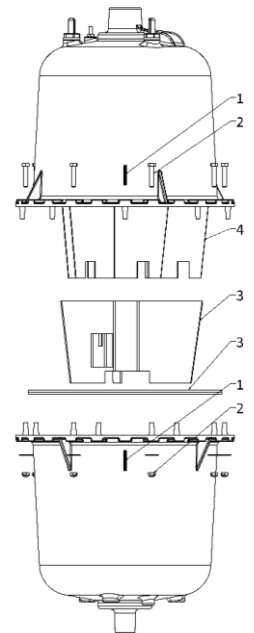

**WARNING!** Never shake the edge of the cylinder shells to remove limescale. It is imperative to systematically replace the cylinder seal and reposition it in its housing. Always replace the sealing ring and insert it into the profile of the lower barrel of the cylinder. Then insert the upper part (electrodes).

Make sure to align the two shells, reposition the nuts and screws. Tighten by screwing the screws opposite each other so that the seal is not deformed.



**WARNING!** If the power cables change, be sure to run them through the steam generator according to the wiring diagram explained previously.



# ElectroVap® STEAM BATH

## 6.5 DRAIN VALVE

The drain valve should be maintained whenever the steam tank is maintained or changed.

- Once the tank is out of the steam generator, disconnect the drain valve supply cables (**Item 1**).
- Unscrew the nut and the plastic protection of the supply coil (**Item 2 & 3**).
- Now you can remove the coil (**Item 4**) from the valve body (**Item 5**).
- Use a pair of pliers or a 19" wrench to unscrew the valve plug (**Item 6**) from the valve body (**Item 5**).
- Check and clean, if necessary, the inside of the valve body by running water through the hole.

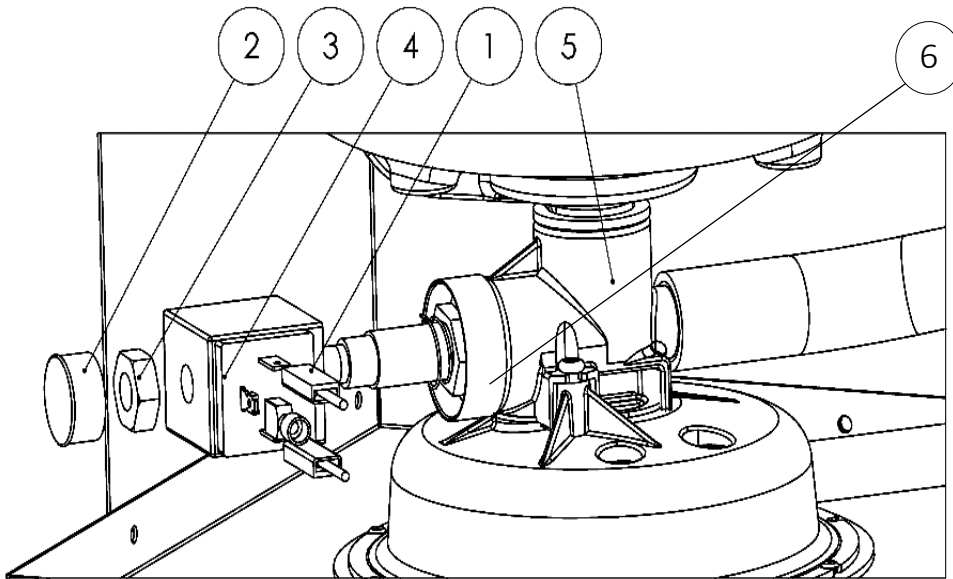

Fig. 6-5. Steam generator drain valve

Reassemble the drain valve as original, before repositioning the tank, by proceeding as follows:

1. Position the tank bottom in the valve connection, push down.
2. Replace the steam hose and do not forget to tighten the hose clamp.

**Ensure that all the clamps are properly tightened whenever the steam generator is maintained.**

# ElectroVap® STEAM BATH

## 6.6 WATER INLET VALVE

Maintenance of the water inlet valve is to be done after the first 50 hours of operation. Thereafter, twice a year (minimum).

- Switch the appliance off.
- Switch off the water supply to the steam generator and unscrew the water supply hose.
- Disconnect the power cables from the water inlet valve of your steam generator (Item 1).
- Loosen the clamp and remove the water supply hose. (Item 2)
- Unscrew the two screws securing the valve (Item 3).
- Pull out your valve, remove the filter with pliers and remove the coil (Item 4) by prying it off with a screwdriver.
- Run water through the valve body and over the filter to remove any particles.

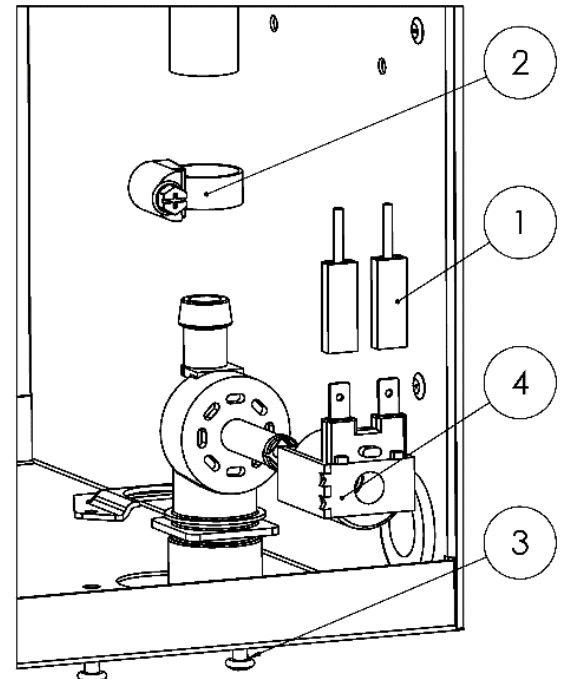

Fig. 6-6. Steam generator water inlet valve

Once all these operations completed, please reassemble the unit, taking care to check the condition of the water supply hose clamp. You can put your appliance back into service.

**Ensure that all the clamps are properly tightened whenever the steam generator is maintained.**



# ElectroVap® STEAM BATH

## 7. SPARE PARTS

### 7.1 HYDRAULIC PART

N°	Code	Description
1	D110136-SC-SP	Complete filling cup for 1 SC
	D110136-MC-SP	Full filling cup for 1 MC
2	D110146-SP	Tightening clamp - 12x22mm
	D110139-SP	Tightening clamp - 16x27mm
	D110140-SP	Tightening clamp - 20x32mm
	D110141-SP	Tightening clamp - 25x40mm
	D108256-SP	Tightening clamp - 40x60mm
4	D110195-SP	Cylinder maintenance kit for 1 SC
	D110196-SP	Cylinder maintenance kit for 1 MC
5	D61898	Pipe - 13/19mm (water supply hose)
	D61899	Pipe - 19/26mm (overflow and cylinder filling hoses)
6	D110157-SP	Water inlet valve ELMC 5-30
	D110771-SP	Water inlet valve ELMC 40-90
7	D110154-SP	Drain cup (upper part)
	D110154-SP	Drain cup (lower part)
8	D116726-24-SP	Complete drain valve 24V
	D110148-24-SP	Operator with 24V coil for drain valve
	D110149-SP	Drain valve body
	D116656-24-SP	Drain valve coil 24V
	D110153-SP	Bag of 10 drain valve gaskets
9	D119698-1SC-SP	3-cable cylinder 1 SC power kit
	D119698-1MC-SP	3-cable cylinder 1 MC power kit
	D119698-2MC-SP	3-cable cylinder 2 MC power kit
	D119698-3MC-SP	3-cable cylinder 3 MC power kit
10	D180509-1SC-SP	1 SC High Level Electrode Cables
	D180509-1MC-SP	1MC High Level Electrode Cables
	D180509-2MC-SP	2MC High Level Electrode Cables
	D180509-3MC-SP	3MC High Level Electrode Cables

(\*) SC = Small Cylinder - MC= Medium Cylinder

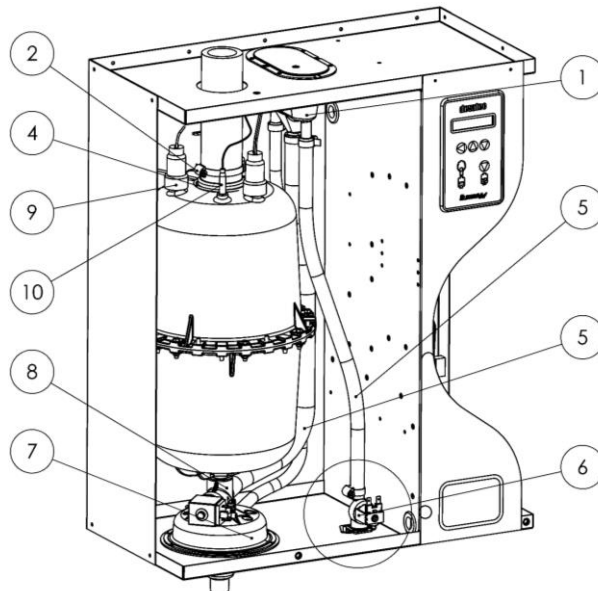

# ElectroVap® STEAM BATH

N°	Code	Description
11	D110214-SP	Set of 3 power electrodes for cylinder SC
	D110217-SP	Set of 3 power electrodes for cylinder MC
12	D110212-SP	SC cylinder seal
	D110213-SP	MC cylinder seal
13	D110221-SP	Brass nut for electrode (Bag of 3)
15	D110233-SP	Bag of screws, nuts, cylinder washers
16	D110209-SP	High level electrode with M4 nuts
17	D110200-SP	MC Electrode spacer
18	D110206-SP	SC cylinder filter
	D110207-SP	MC cylinder filter

(\*) SC = Small Cylinder - MC= Medium Cylinder

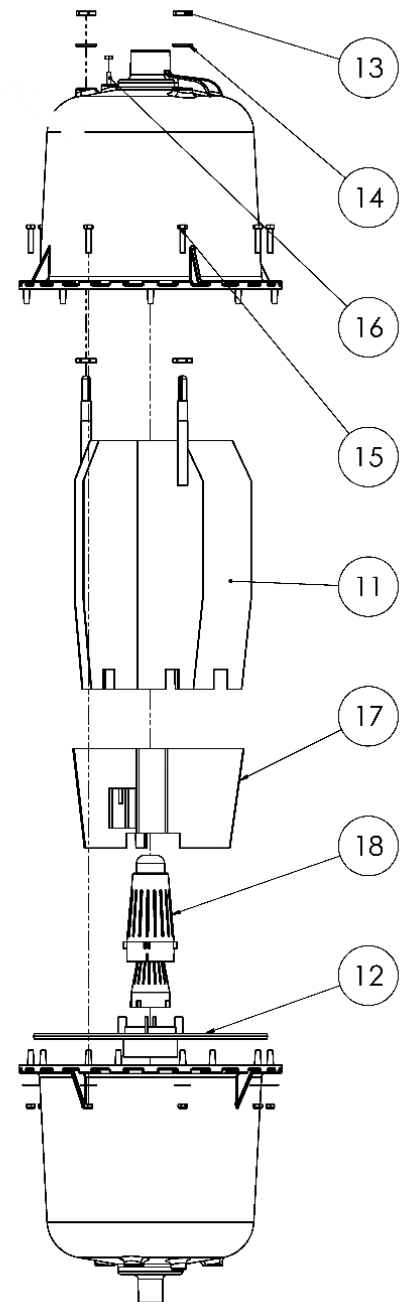
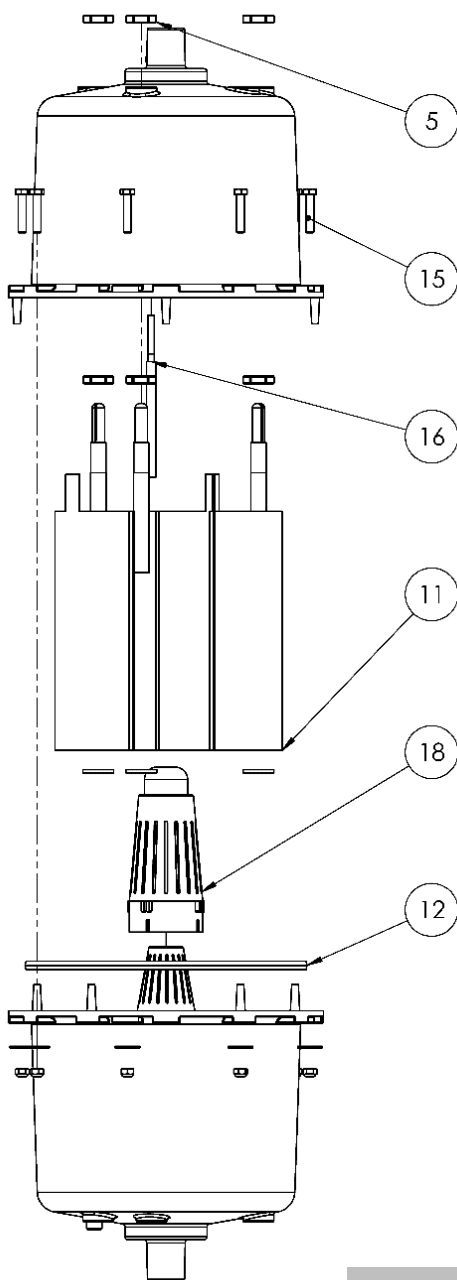

Fig. 7-1. Tank exploded view

# ElectroVap® STEAM BATH

## 7.2 WATER INLET VALVE

N°	Code	Description
1-2	D110157-SP	Water inlet valve (1 cylinder)
1-2	D110771-SP	Water inlet valve (2-3 cylinders)
2	D116655-24	Coil 24V
	D116655-24-UL	UL coil 24V
3	D111775-SP	Valve bracket

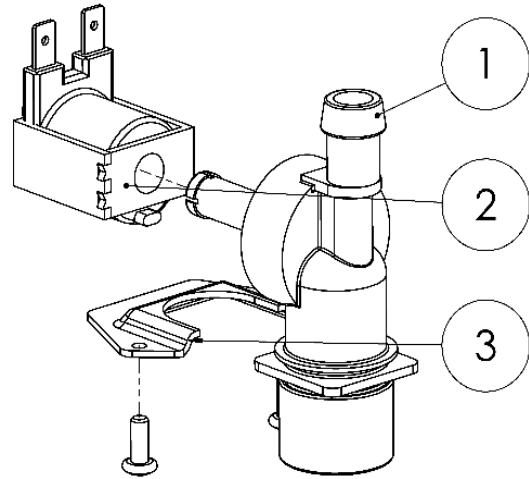

Fig. 7-2. Water inlet valve exploded view

## 7.3 DRAINING CIRCUIT

N°	Code	Description
1 - 5 & 8 - 10	D110147-SP	Complete valve (1 to 5)
1		Adapter ring
2		Protective ring
3	D110153-SP	O-ring seal (set of 10)
5	D110149-SP	Valve body
6	D110154-SP	Drain cup upper part
7	D110155-SP	Drain cup lower part
8	D110148-10-SP	Nut protection
9	D116656-24-SP	Drain valve coil
	D116656-24-UL-SP	UL drain valve coil
4 - 10	D110148-SP	Valve pilot kit 24 VAC
	D110148-UL-SP	Valve pilot kit 24 VAC (UL)

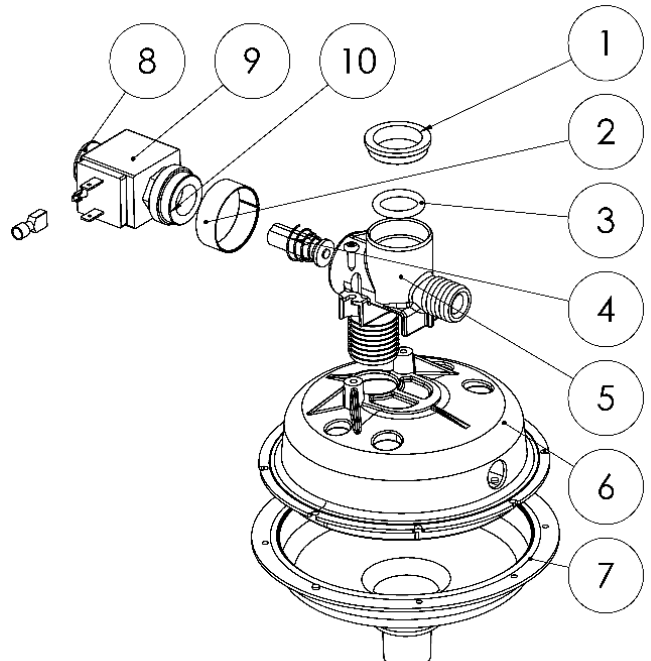

Fig. 7-3. Draining circuit exploded view

# ElectroVap® STEAM BATH

## 7.4 ELECTRICAL PART

N°	Code	Description
20	D121389-1-SP	Main Board ELMC 5-30 (1TI)
	D121388-1-SP	Main Board ELMC 40-90 (0TI)
21	D110766-SP	Board / module 2 TI ELMC 40-60
	D110186-SP	Board / module 3 TI ELMC 70-90
22	D50931-SP	Remote information board
23	D110124-SP	Display Board
24	D50932-SP	Contacteur 24 VAC
25	D92393-SP	Switch on/off
26	D110128-50-SP	Transformer: Prim: 2x115V / Sec: 2x12V
27	D116631-SP	Fuse fast 2A (Bag of 6)
28	D116718-SP	Fuse fast 5A (Bag of 6)
30	D109737-SP	Terminal block 35mm <sup>2</sup> (L1, L2, L3)
31	D110168-SP	Terminal block 16mm <sup>2</sup> (L, N)
32	D110768-SP	Fuse protection terminal 6mm <sup>2</sup> .
33	D107491-SP	Terminal block (1, 2, 3, 4)
34	D110166-SP	End terminal block
35	D110163-SP	Ground terminal block 35mm <sup>2</sup>

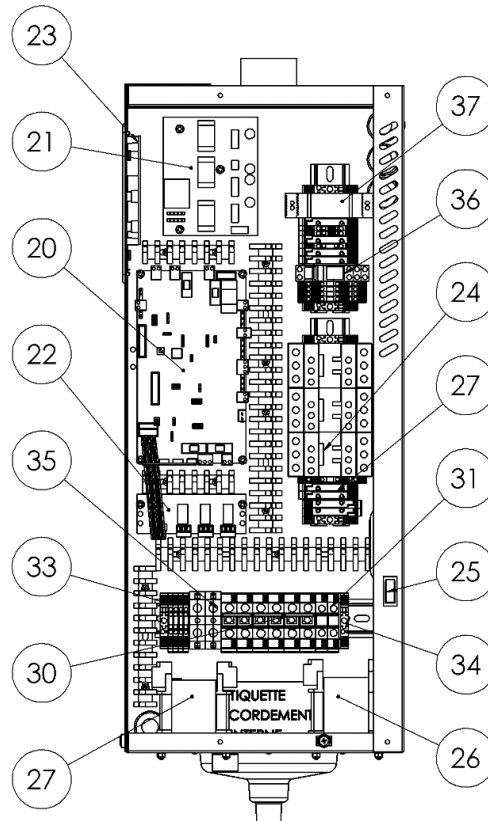
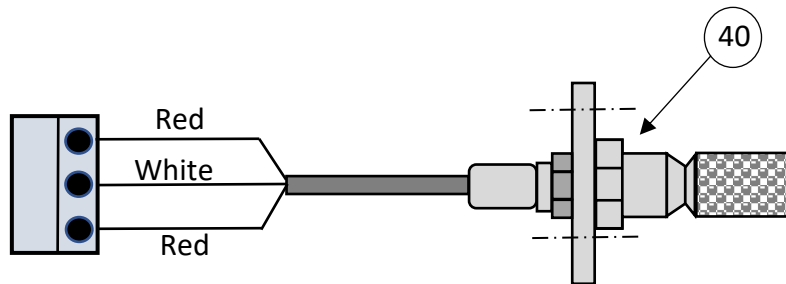

Fig. 7-4. Steam generator electrical compartment

# ElectroVap® STEAM BATH

## 7.5 TEMPERATURE SENSOR



N°	Code	Description
40	930318	Temperature probe KTY81 / 3 wires / 10m
	D116655	Temperature probe KTY81 / 3 wires / 25m

## 7.6 FUSES

Location	Amp.	Fuse protection
F1	2AT	Power contactor coil
F2	2AT	Inlet valve coil
F3	2AT	Drain valve coil
F4	2AT	Electronic boards
Din rail 5 & 6	2AT	Transformer
Din rail 7 & 8	5AT	Transformer



185, Boulevard des Frères Rousseau  
76550 Offranville – France  
[www.devatec.com](http://www.devatec.com)

**Export**→ Tel. +33 (0)2 35 83 06 44  
Email : [export@devatec.com](mailto:export@devatec.com)

**France**→ Tel. +33 (0)2 35 04 61 41  
Email : [france@devatec.com](mailto:france@devatec.com)